



Jauch Battery Solutions

- Low self-discharge
- Long shelf life
- Un 38.3 tested



RoHS compliant



Pb free



REACH compliant



Conflict mineral free

Technical Data Sheet · FR6

SPECIFICATIONS

Cell Size reference	FR 6 AA L91
Nominal Voltage	1.5V
Jauch part number	253815
Storage Temperature	5°C to 30°C
Operating Temperature	-40°C to + 60°C
Weight	Approx. 14.5 gr.
Typical Volume	8.0 cubic centimeter
Max Discharge (single battery only)	2.5 Amps Continuous
Lithium Content	Less than 1 gram
Typical IR	110 to 240 milliohms
Shelf Life	10 years at 23°C
Chemistry	Li/FeS ₂
Designation	ANSI 15-LF, IEC-FR14505

DIMENSION

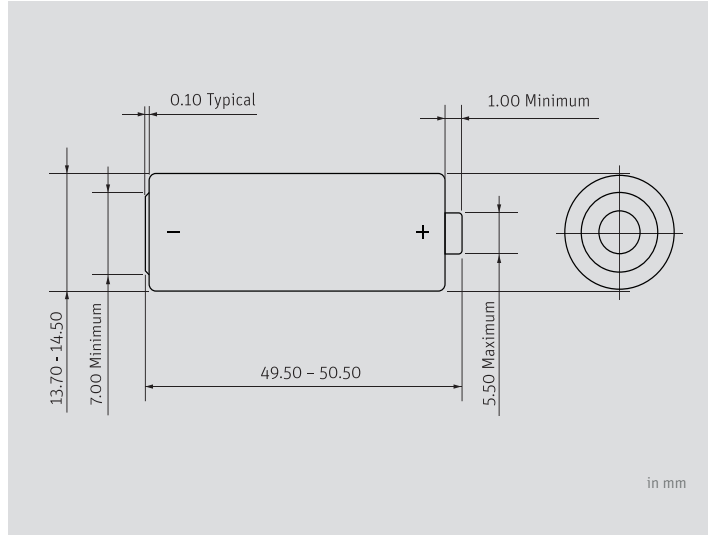

DISCHARGE PROFILE

Constant Current Discharge

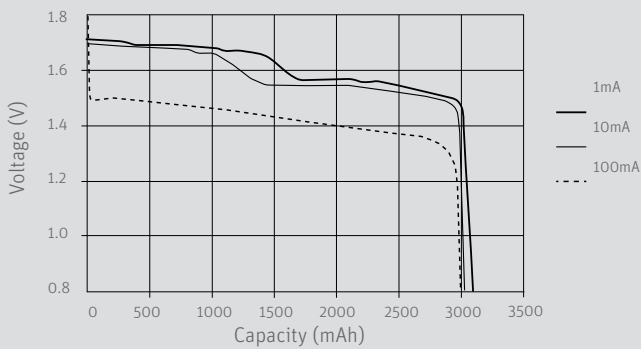

MILLIAMPER-HOURS CAPACITY

Constant Current Discharge to 0.8 Volts

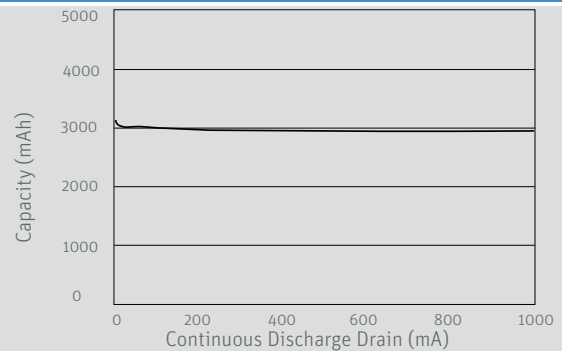

INTERNAL RESISTANCE PROFILE

Cell Ohmic Resistance

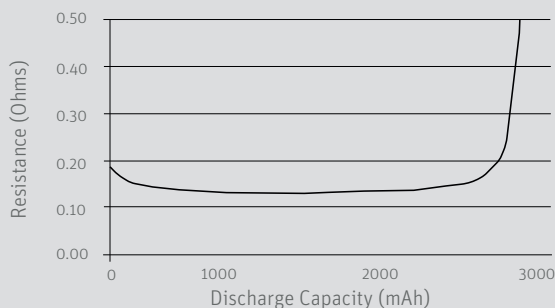

CONSTANT CURRENT PERFORMANCE

Characteristics to 0.8 Volts

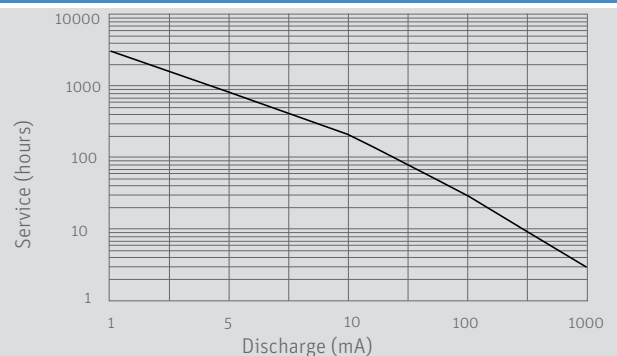



Jauch Battery Solutions

- Low self-discharge
- Long shelf life
- Un 38.3 tested



RoHS compliant



Pb free



REACH compliant



Conflict mineral free

Technical Data Sheet · FR6

APPLICATION TEST

REMOTE/RADIO /CLOCK
50 mA 1 hr/8 hrs day

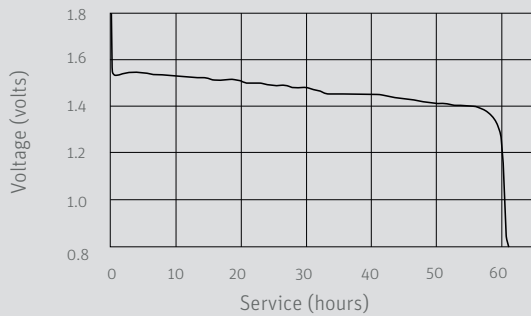

APPLICATION TEST

CD/GAMES
250 mA 1hr/day

DIGITALAUDIO
100 mA 1 hr/day

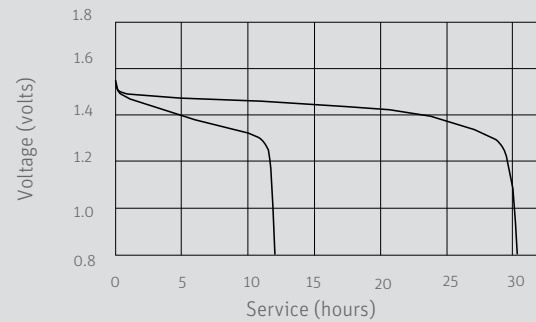

APPLICATION TEST

PORTABLE LIGHTING
3.3 ohm 24hr/day

TOY
3.9 ohm 1 hr/day



INDUSTRY STANDARD TESTS

DIGITAL CAMERA
1500mW2s,650mW28s,10T/h,24h/d

