



actual size

Oscillator JOH21 · HCSL

- SMD Low Voltage HCSL Oscillator, 2.0 x 1.6 mm
- superior phase jitter (60fs RMS max. at 156.250 MHz)
- drives fast HCSL logic
- complementary output, low EMI
- compact & flat ceramic / metal package



RoHS compliant



Pb free



REACH compliant



Conflict mineral free

GENERAL DATA		JOH21 1.8 V / 2.5 V / 3.3 V
TYPE		JOH21 1.8 V / 2.5 V / 3.3 V
frequency range		100.0 ~ 160.0 MHz
frequency stability over all*		±50 ppm ~ ±100 ppm (see table 1)
current consumption		40 mA max.
supply voltage V _{DC}		1.8 V ±5 % / 2.5 V ±5 % / 3.3 V ±5 %
temperature	operating	-20 °C ~ +70 °C (T0)
		-40 °C ~ +85 °C (T1)
		-40 °C ~ +105 °C (T2 Δ)
		-40 °C ~ +125 °C (T3 Δ)
	storage	-55 °C ~ +125 °C
output	rise & fall time	0.6 ns (20 % ~ 80 % of V _{pp})
	slew rate	1 V/ns min. / 4 V/ns max. (V _c : 0.35 V ±0.15 V)
	load nom.	50 Ω to GND at each output
	SE swing	0.55 V _{p-p} min. / 0.65 V _{p-p} typ.
	"H" level	+500 mV min. / +1000 mV max.
	"L" level	-150 mV min. / +150 mV max.
output enable time max.		5 ms
output disable time max.		200 ns
start-up time max.		5 ms
phase jitter 12 kHz ~ 20.0 MHz		see table 2
symmetry at 50% of V _{pp}		45 % ~ 55 % max.

Δ ask for availability of higher temperature ranges and frequency stabilities

TABLE 1: FREQUENCY STABILITY CODE					
stability code		A	B	G	C
temp. code*		±100 ppm	±50 ppm	±30 ppm	±25 ppm
-20 °C ~ +70 °C	T0	○	○	Δ	Δ
-40 °C ~ +85 °C	T1	○	○	Δ	
-40 °C ~ +105 °C	T2 Δ	Δ	Δ		
-40 °C ~ +125 °C	T3 Δ	Δ			

* includes stability at 25 °C, operating temp. range, supply voltage change, shock and vibration, aging 1st year.

ENABLE / DISABLE FUNCTION	
pin #1 (e/d control)	pin #4 / #5 (outputs)
V _{ED} ≥ 0.7 V _{DC} (use external pull-up resistor)	active
gnd or V _{ED} ≤ 0.3 V _{DC}	high impedance, low stby. current
standby function	stop
standby current max.	5 μA

TABLE 2: PHASE JITTER INFORMATION		
at V _{DC} = 3.3 V	RMS phase jitter (offset 12 kHz ~ 20.0 MHz)	
typical frequency f _o	typical	maximum
156.250 MHz	45 fs RMS	< 60 fs RMS*
125.0 MHz	60 fs RMS	< 80 fs RMS*
100.0 MHz	70 fs RMS	< 100 fs RMS*

* the suffix -SP is always added to the description of these very low noise oscillators (see order information)

DIMENSIONS			
top view	side view	bottom view	pad layout
<p>XO JOH21 #1: e/d #2: not connected #3: GND #4: output 1 #5: output 2 #6: V_{DC}</p>			pin connection
			in mm

ORDER INFORMATION						
0	frequency	type	frequency stability code	supply voltage code	option	superior phase noise
Oscillator	100.0 ~ 160.0 MHz	JOH21	see table 1	1.8 = 1.8 V 2.5 = 2.5 V 3.3 = 3.3 V	T0 = -20 °C ~ +70 °C T1 = -40 °C ~ +85 °C T2 = -40 °C ~ +105 °C T3 = -40 °C ~ +125 °C	SP = improved phase noise please ask
Example: 0 156.250-JOH21-B-3.3-T1-SP-LF (Suffix LF = RoHS compliant / Pb free)						

Oscillator JOH21 · HCSL

TAPING SPECIFICATION

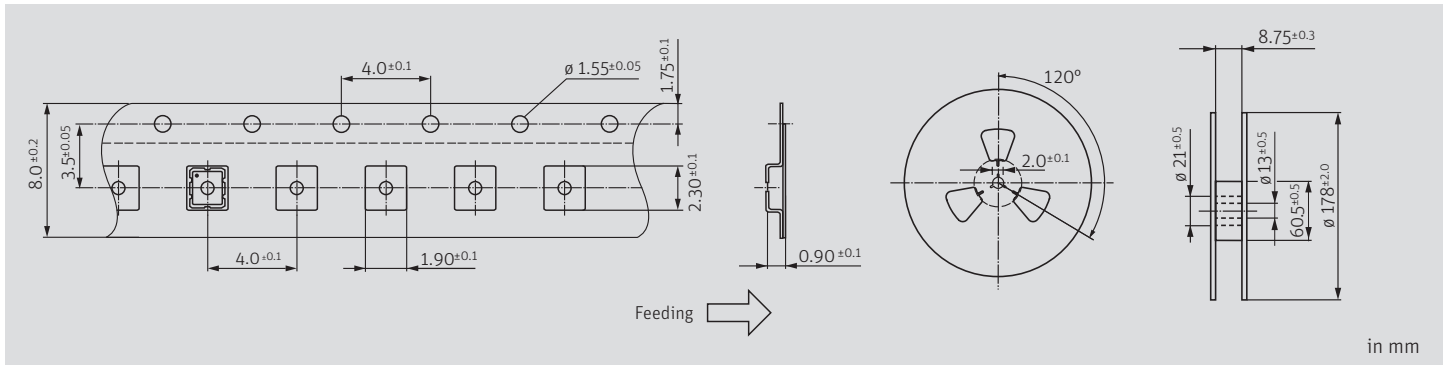

REFLOW SOLDERING PROFILE

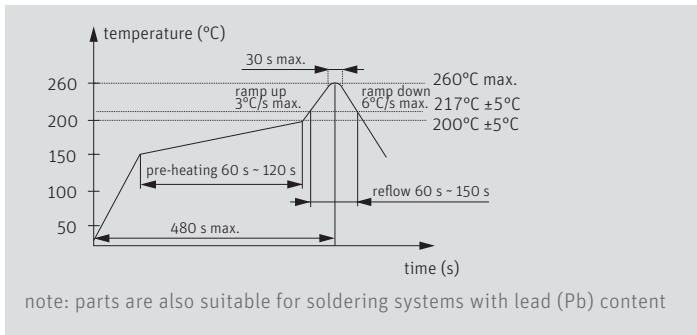

MARKING

frequency

□ F H S & date code

date code: A ~ M: Jan. - Dec.

5: 2025 6: 2026 7: 2027 8: 2028 9: 2029 0: 2030

Jan.	Febr.	Mar.	Apr.	May	June
A	B	C	D	E	F
July	Aug.	Sept.	Oct.	Nov.	Dec.
G	H	J	K	L	M

PACKAGING NOTE

- standard packing unit is 3000 pieces per reel
- non-multiple packing units are only supplied taped / bulk