

actual size

Oscillator JT21LE · low voltage TCXO

- temp. compensated crystal oscillator, 2.0 x 1.6 mm
- 1.2V ~ 1.8V low voltage TCXO with clipped sine output
- temp. range -40 °C ~ +85 °C and ± 0.5 ppm stability available
- with energy-saving standby function
- for navigation system use, please prefer JT21GLE



RoHS compliant



Pb free



REACH compliant



Conflict mineral free

GENERAL DATA		JT21LE clipped sine low voltage TCXO
frequency range		13.0 ~ 52.0 MHz
frequency tolerance/ stability	at +25°C	±2.0 ppm (incl. 2x reflow)
	temperature	±0.5 ppm ~ ±5 ppm (table 1)
	aging first year	±1 ppm
	supply voltage	±0.2 ppm (at any V _{DC} ±5%)
	load change	±0.2 ppm (at 10 KΩ 10 pF ±10%)
current consumption		2.0 mA max. <26 MHz / 2.5 mA max. <52 MHz
supply voltage V _{DC}		1.2 V -5% ~ 1.8 V +5% (variable)
temperature	operating	see table 1
	storage	-40 °C ~ +85 °C
output	load nom.	10 KΩ // 10 pF
	level min.	0.8 V _{pp} (clipped sine)
standby function		stop function, see table 2
disabled supply current		0.1 µA typ. / 1.0 µA max.
start-up time max.		3.0 ms
enable time max.		3.0 ms
disable time max.		150 ns
phase noise at f _o 26 MHz	at 100 Hz	-116 dBc/Hz typ.
	at 1 KHz	-135 dBc/Hz typ.
	at 10 KHz	-148 dBc/Hz typ.

TABLE 1: FREQUENCY STABILITY VS. TEMPERATURE							
operating temperature code	frequency stability code / ppm						
	Y	Z	A	B	C	D	E
± 5.0	± 3.0	± 2.5	± 2.0	± 1.5	± 1.0	± 0.5	
A: -30 °C ~ +80 °C	○	○	○	○	○	○	○
B: -20 °C ~ +70 °C	○	○	○	○	○	○	○
C: -10 °C ~ +60 °C	○	○	○	○	○	○	○
D: 0 °C ~ +85 °C	○	○	○	○	○	○	○
E: 0 °C ~ +55 °C	○	○	○	○	○	○	○
F: -10 °C ~ +70 °C	○	○	○	○	○	○	○
G: -30 °C ~ +75 °C	○	○	○	○	○	○	○
H: -20 °C ~ +75 °C	○	○	○	○	○	○	○
K: -40 °C ~ +85 °C	○	○	○	○	○	○	○
L: -20 °C ~ +85 °C	○	○	○	○	○	○	○
M: -30 °C ~ +85 °C	○	○	○	○	○	○	○

○ on request

TABLE 2: ENABLE / DISABLE FUNCTION	
PIN #1 (E/D CONTROL)	PIN #3 (OUTPUT)
high "1" (VIH ≥ 0.8 VDC)	active (see information below)
low "0" (VIL ≤ 0.2 VDC)	oscillator stops, output high impedance
Important: To activate the TCXO permanently, please connect an external pull-up resistor of 10 kΩ to pin #1	

DIMENSIONS

top view

side view

bottom view

pad layout

TCXO
JT21LE
1: e/d
2: GND
3: output
4: V_{DC}

pin connection

in mm

ORDER INFORMATION

0	frequency	type	frequency stability code	operating temp. code	supply voltage code
Oscillator	13.0 ~ 52.0 MHz	JT21LE = TCXO	A - Z see table 1	A - M see table 1	V = variable supply voltage 1.2 V -5% ~ 1.8 V +5%

Example: 0 26.0-JT21LE-A-G-V-LF (Suffix LF = RoHS compliant / Pb free)

Oscillator JT21LE · low voltage TCXO

TAPING SPECIFICATION

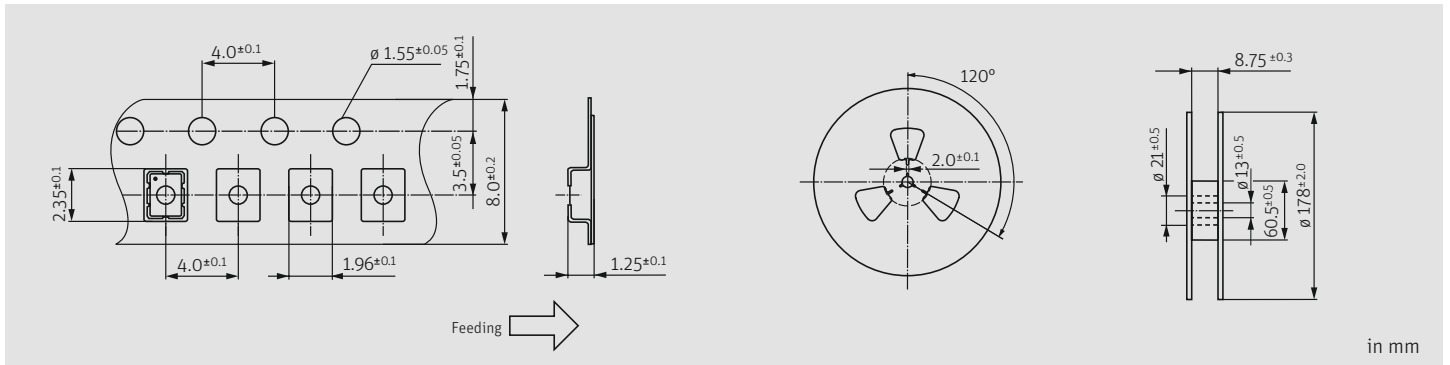

REFLOW SOLDERING PROFILE

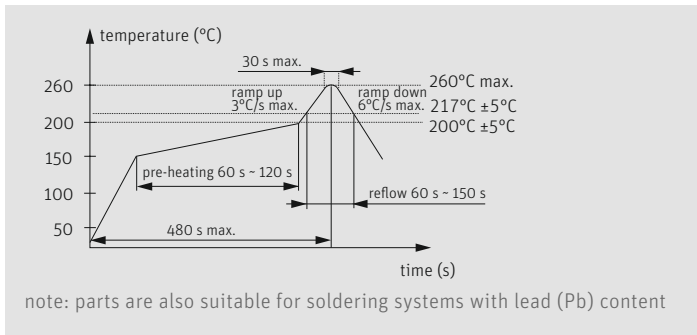

MARKING

frequency

company code / stability code / date code

date code: A ~ M: Jan. - Dec.

4: 2024 5: 2025 6: 2026 7: 2027 8: 2028 9: 2029

Jan.	Febr.	Mar.	Apr.	May	June
A	B	C	D	E	F
July	Aug.	Sept.	Oct.	Nov.	Dec.
G	H	J	K	L	M

PACKAGING NOTE

- standard packing unit is 3000 pieces per reel
- customized quantities on request