

Jauch crystals for IoT applications

There's a new buzzword on everybody's lips – IoT. IoT stands for Internet of Things and suggests that every device or application that belongs to the world of IoT can communicate with each other.

Most of this IoT networked communication is wireless communication, however there are several competing standards that aren't necessarily compatible with each other.

Here are a few examples of competing wireless standards and ASIC suppliers that provide solutions for IoT wireless communication. The list below also includes standards and abbreviations of other standards for information exchange over the air.

List of IoT and other Wireless Standards

BT®	= B luetooth®
BLE®	= B luetooth® L ow E nergy (also Bluetooth Smart)
IEEE® 802.15.4	= IEEE Standard for Low-Rate Wireless Networks
IEEE® 802.11 b/g/n	= W ireless L AN Medium Access Control (MAC) and Physical Layer (PHY) Specifications
LoRa®	= Long Range (low data rate) for IoT, proprietary modulation of RF
SigFox®	= a company offering wireless services for IoT, proprietary modulation
ISO/IEC 14443	= Identification cards - Contactless integrated circuit(s) cards - Proximity cards (-> RFID)
ISO/IEC 15693	= Identification cards - Contactless integrated circuit cards - Vicinity cards (-> RFID)
ISO/IEC 18000	= Information technology — Radio frequency identification for item management (-> RFID)

List of further Wireless Standards, Wireless Transmission Protocols and Abbreviations

WLAN	= W ireless L ocal A rea N etwork, based on IEEE® 802.11 b/g/n
WiFi	= WiFi Alliance -> Organization that certifies devices according to the WLAN Standard
SimpleLink WiFi	= Link to WiFi Standards IEEE® 802.11 b/g/n
ZigBee®	= ZigBee Alliance -> Companies who defined the ZigBee® Standard, based on IEEE® 802.15.4
ZigBee® RF4CE	= Radio Frequency for Consumer Electronics (for remote controls) based on IEEE® 802.15.4
6LowPan	= IPv6 over Low Power Wireless Personal Area Networks, based on IEEE® 802.15.4
NFC	= N ear F ield C ommunication, standard defined by members of the NFC-Forum
RFID	= R adio F requency I dentification, based on several ISO/IEC standards
LPWAN	= L ow P ower W ide A rea N etworks
ISM	= I ndustrial, S cientific and M edical Band
GSM	= G lobal S ystem for M obile Communications
DECT	= D igital E nhanced C ordless T elecommunications

Jauch crystals for IoT applications

Typical ASIC and SoC suppliers for RF / Wireless applications

- TI (Texas Instruments)
- Broadcom
- NXP/Philips
- Cambridge Silicon Radio (CSR)
- Nordic Semiconductor
- ST Microelectronics
- Microchip
- Renesas
- Silicon Labs
- Freescale
- Cypress
- EM Microelectronic
- Legic
- Atmel
- Semtech
- Marvell

... and many more ...

Depending on the system architecture, the ASICs (Application Specific ICs) contain the RF-function for transmission and reception of wirelessly distributed information, or even combine the MCU and the RF-function in one package. Typically, these ASICs are called RF-SoCs standing for Radio Frequency System on Chip.

The RF-function requires a reference clock in the MHz range, whereas the RF-SoCs might additionally require a tuning fork (TF) crystal. This TF crystal might be used for standby or timekeeping functions of the MCU part of the SoC.

Depending on the supported wireless standard, typically one of the frequencies in the list below is used as a MHz reference clock for the RF-section of the ASIC or SoC.

Typical frequencies for wireless applications

Frequency [MHz]	Wireless Standard
13.560	RFID
16.0	WiFi, ZigBee, BT, BLE
19.2	DECT, GPS, BLE
20.0	WiFi, BT
24.0	WiFi, BT, BLE
25.0	ISM
26.0	WLAN, WiFi, BT, BLE, GSM, NFC
27.120	RFID
30.0	ISM
32.0	ZigBee, BT, BLE, 6LowPan, RF4CE, LoRa
37.4	WiFi, BT
38.4	DECT, WiFi, BT
40.0	WiFi, BT, BLE, NFC, SimpleLink
48.0	WiFi, BT
52.0	WLAN, WiFi, GSM

Jauch crystals for IoT applications

Requirements for Crystals in Wireless Applications

Generally, RF (Radio Frequency) circuits transmit and receive radio waves in predefined and narrow frequency bands. To avoid any interference with other frequency bands, and to improve reception sensitivity for long distance transmission, the overall frequency accuracy may be limited to a few tens of ppm's relative to the specified reference RF frequency.

Most RF receivers or transmitters typically use AT-cut crystals with frequencies in the range of 13.560MHz to 52.0MHz to create a reference frequency that is used to generate RF reception or transmission frequencies at several hundreds of MHz or even in the GHz range.

As the accuracy of the crystal-based reference frequency (measured in ppm) converts to the RF range, strong requirements apply to the frequency accuracy and stability of the reference clock generated by the crystal.

Accordingly, strict specifications may apply to the frequency tolerance, the frequency stability and the aging of the crystal over the expected lifetime of the customer's product.

Furthermore, the crystal-based reference clock should be free of spurious frequencies, which could cause an unwanted RF transmission at frequencies close to the actual RF transmission carrier frequency.

Total "ppm" Budget for Wireless Applications

According to the RF / wireless standards being used, different total "ppm" budgets are valid. Some RF standards require a total "ppm" budget as narrow as +/-20ppm, whereas in others +/-40ppm is acceptable.

How to meet +/-20ppm "overall" with a Crystal

If the total "ppm" budget is only +/-20ppm, it means that the overall frequency stability of the MHz reference clock including all contributions like frequency tolerance at +25°C, frequency stability over the operating temp range, long term aging and frequency pulling due to load capacitance tolerance should be kept below +/-20ppm, which isn't an easy task if using crystals.

Some RF-ASICs or RF-SoCs offer the possibility to compensate the frequency tolerance at +25°C and the frequency pulling due to load capacitance tolerance by a module per module frequency compensation.

Two of the frequency compensation methods that can be applied are either the fine-tuning of the frequency synthesizer that generates the RF frequency based on the crystal frequency, or by load capacitance tuning of the built-in crystal load capacitors inside the RF-ASIC.

In case of doubt, the RF-ASIC datasheet should include information which frequency compensation method is recommended by the IC supplier for their RF-chip.

Jauch crystals for IoT applications

Please find below a table that helps to understand which contributions to the overall ppm budget can optionally be compensated by individual frequency compensation, and which contributions are variable over temperature (i.e. F/T) or can't be predicted at the time of manufacturing (i.e. aging).

Example Q 26,0-JXS32-CL-10/13-T(-30/+85)-FU-WA-LF:

contributions to frequency offset & stability		initial	if compensated
Frequency tolerance @ 25°C max. :	[ppm]	+/-10	+/-2
Frequency shift due to CL tolerance / mismatch (estimated) :	[ppm]	+/-10	incl. in above
Frequency stability (F/T) over specified temperature range - 30 ~ +85°C :	[ppm]	+/-13	+/-13
Aging first year :	[ppm]	(+/-1)	
Aging after 7 years (1 st year included) :	[ppm]	+/-5	+/-5
→ Overall max. frequency variation after 7 years :	[ppm]	+/-38	+/-20

The example above shows that a “ppm” limit of +/-20ppm can only be achieved if a cancellation of the frequency tolerance and the frequency shift due to load capacitance tolerance / mismatch is done individually, i.e. module per module.

However, the contributions of frequency stability (F/T) and long-term aging can't be compensated at the time of production. That is why the contribution of the long-term aging should be low over the lifetime of the final product, and the frequency stability should be properly selected from the options shown in the Jauch JXS-WA crystal datasheets for wireless applications.

If the cancellation of the frequency tolerance and the frequency shift due to load capacitance tolerance / mismatch isn't carried out, in the example shown above the “ppm” budget including long term aging will be close to +/-40ppm.

Please refer to the documents of the corresponding RF standard, which should contain the information of the acceptable overall “ppm” budget.

Please note that the overall “ppm” budget might depend on the RF-frequency and RF-bandwidth.

The datasheet provided by the ASIC / RF-SoC supplier will contain an advice to choose the appropriate overall frequency stability for the crystal, however please take the abovementioned table into account.

Jauch crystals for IoT applications

Prevention of Spurious Modes

As already stated, there's one more important aspect in addition to the overall frequency stability aspect that is worth looking at – the prevention of spurious frequencies in the RF-band. In simple words, the reference signal supplied to RF-ASICs and RF-SoCs should be pure and free of extra frequencies / resonances. The quality and purity of the RF-signal is typically being evaluated by signal spectrum analysis.

See below a few spectrum analysis plots that demonstrate the difference between an RF-signal derived from a dedicated Jauch crystal for wireless applications (JXS-WA) vs. a crystal with a standard specification.

Bad RF spectrum at 2.4GHz caused by a standard crystal with spurious resonances

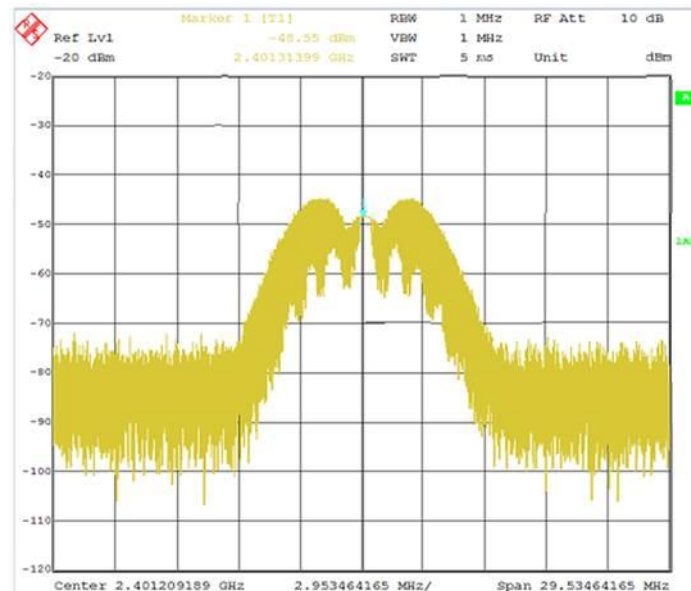

Good RF spectrum of the same circuit using a Jauch crystal for Wireless Applications

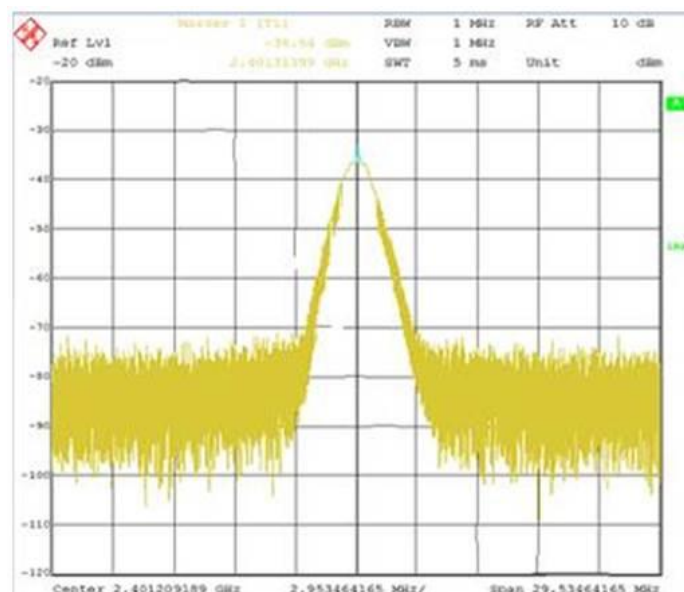

Jauch crystals for IoT applications

Bad reference frequency spectrum of a 26.0MHz standard crystal

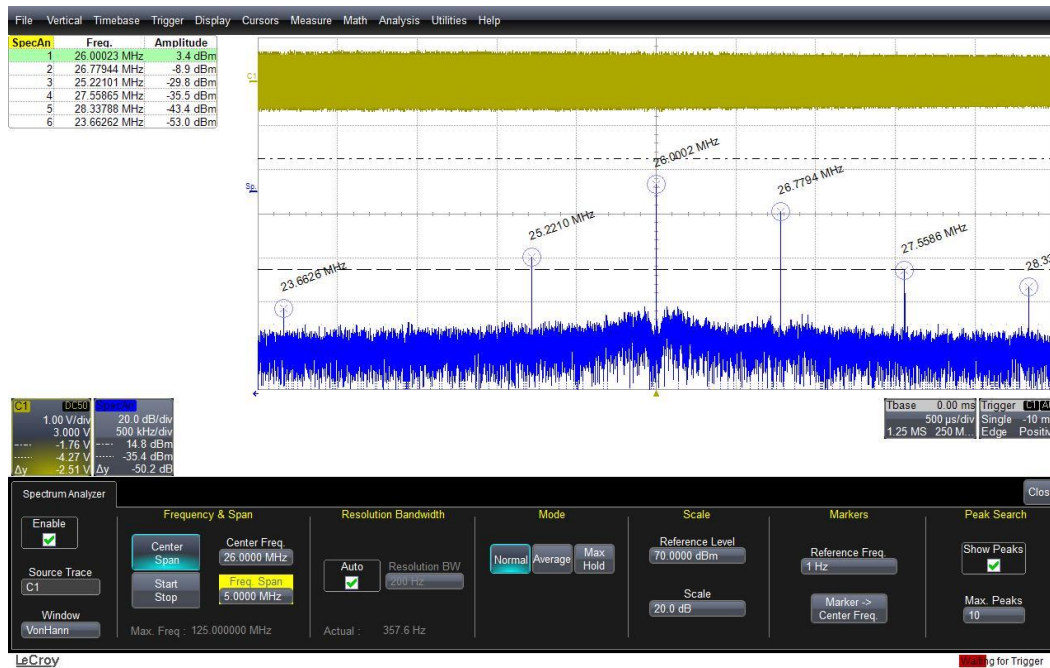

Good reference frequency spectrum of a 26.0MHz Jauch crystal for Wireless Applications

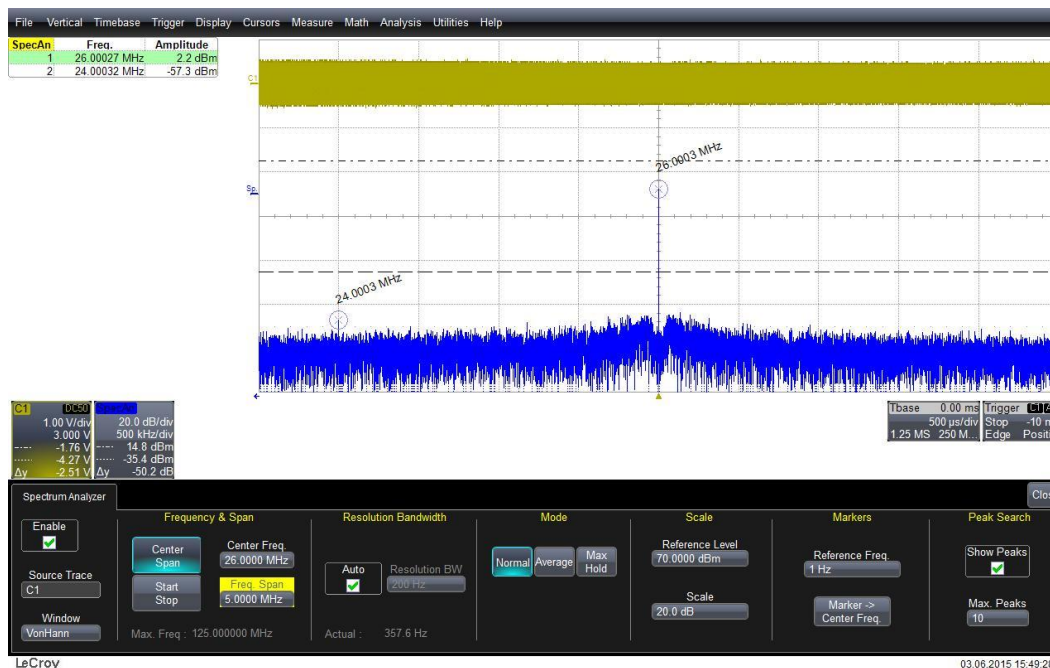

Low series resistance (ESR) for high loop gain margin

Most RF ASICs and SOCs use an integrated inverter amplifier to drive the resonant loop built by the crystal and 2 external capacitors C_{L1} and C_{L2} . This typical configuration is called Pierce configuration, and may contain an additional feedback resistor to stabilize the DC operating point.

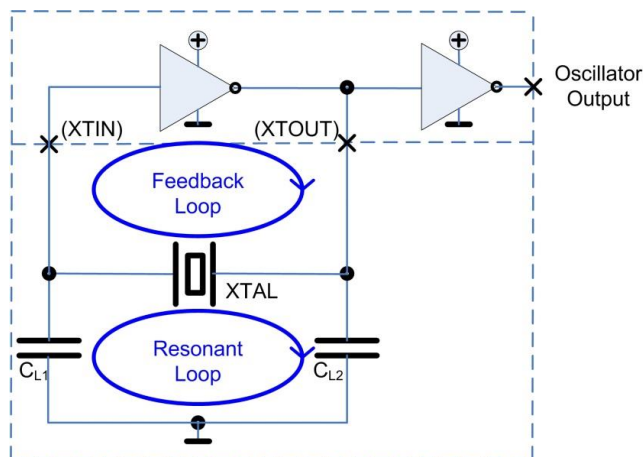

If the datasheet of the RF ASIC contains the information of the inverter amplifier's transconductance, the gain margin of the reference clock circuit built by the inverter amplifier in the feedback loop and the external crystal circuit building the resonant loop can be calculated.

- (1) g_m = inverter amplifier's transconductance in [mA/V] or [μ A/V]
- (2) $g_{m_{crit}}$ = limit of transconductance value to ensure oscillation, also in [mA/V] or [μ A/V]
- (3) $G_M = g_m / g_{m_{crit}}$

In the frequency control industry it's a common understanding that the gain margin G_M (also often called OSF = oscillation safety factor or oscillation allowance) should be > 5 , which ensures a proper operation of the crystal resonant circuit at all environmental conditions and process variations that an RF circuit might be exposed to.

The contribution of the crystal equivalent data to the gain margin G_M can be calculated as follows:

$$(4) \quad g_{m_{crit}} = 4 * R_m * (2\pi f)^2 * (C_0 + C_L)^2$$

with

R_m = motional series resistance of the crystal (often also called ESR)

C_0 = shunt capacitance of the crystal

C_L = load capacitance, built by the two capacitors in the Pierce configuration

Assuming a given value of g_m of the inverter amplifier inside the RF ASIC, it becomes obvious that the gain margin G_M can only be increased if $g_{m_{crit}}$ is decreased.

Jauch crystals for IoT applications

In smaller crystals like the Jauch JXS32, JXS22 and JXS21 for wireless applications the typical value of C_0 is $< 1.3\text{pF}$. That's why g_{mcrit} mostly depends on the series resistance R_m and the selection of the load capacitance C_L .

By an optimized crystal blank design & processing, Jauch is able to offer the JXS-WA crystal series at typical RF reference frequencies with lowest values for the series resistance R_m .

This ensures a safe gain margin G_M and a low power consumption for a reliable operation of your RF circuit.

Summary of key features of Jauch JXS-WA crystals for wireless applications:

- available at typical reference clock frequencies for many RF ASICs and SOCs
- low frequency tolerance
- high frequency stability over temperature
- lowest aging for reliable long-term operation
- optimized crystal design to keep spurious modes low
- low series resistance / ESR for best gain margin and low power consumption

Standards can be found here:

IEEE®	http://ieeexplore.ieee.org/Xplore/home.jsp
ISO	https://www.iso.org/home.html
Bluetooth®	https://www.bluetooth.com/specifications/bluetooth-core-specification
ZigBee®	http://www.zigbee.org/zigbee-for-developers/zigbee-3-0/
LoRa®	https://www.lora-alliance.org/lorawan-for-developers
SigFox®	https://www.sigfox.com/en

References:

BLE:	Freescale AN5177; https://www.nxp.com/docs/en/application-note/AN5177.pdf
RFID:	http://www.atmel.com/images/doc2056.pdf
IEEE 802.15.4:	Freescale AN3251 http://cache.freescale.com/files/rf_if/doc/app_note/AN3251.pdf
General Info:	https://www.ti.com/seclit/wp/swry016/swry016.pdf