

1. Part No. Expression:

STX55I6R3KA11D

(a) (b) (c) (d) (e) (f)

- a) Series code
- b) Dimension code
- c) Inductance code
- d) Tolerance code
- e) Qi design type
- f) Double Layer

2. Configuration & Dimensions :

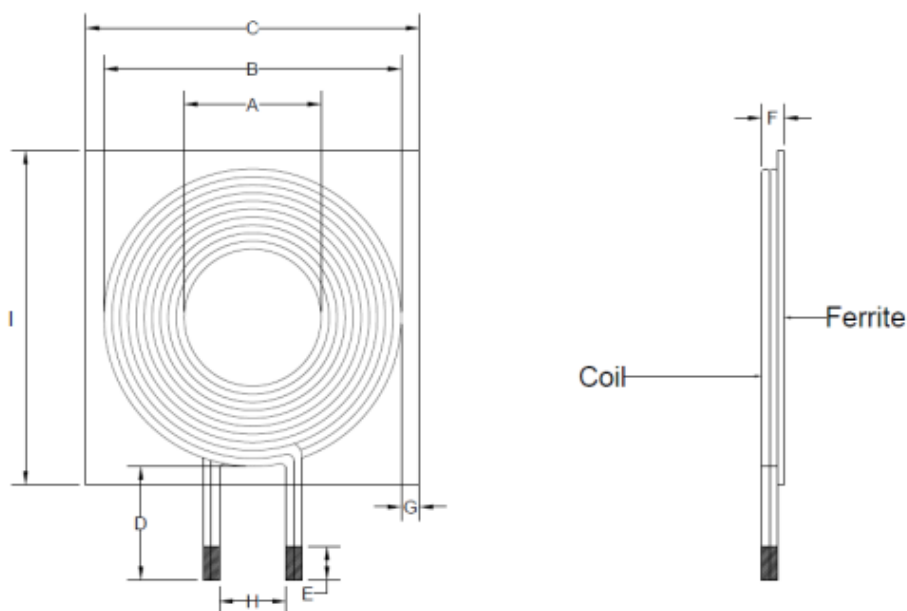

Unit: mm

A	B	C	D	E	F	G	H	I
20.5±0.5	44.0±1.5	50.0±0.5	17.0±1.0	5.0±1.0	3.5±0.5	2.0 Min	10.0 Typ	50.0±0.5

3. Schematic



4. Electrical Characteristics

Inductance (uH)	Test Frequency (Hz)	DCR Max. (mΩ)	Irms Max. (A)
6.3±10%	1V/100K	25	10.0

5. General Specification:

- a) Operating Temp. : -25°C ~ +85°C
- b) Storage Temp. : -40°C ~ +85°C (on board)
- c) Irms: Base on temp. rise up to 40°C Max.