

1. Part No. Expression:

SCT5044026R3KA11S

(a) (b) (c) (d) (e) (f)

- a) Series code
- b) Dimension code
- c) Inductance code
- d) Tolerance code
- e) Qi design type
- f) Single Layer

2. Configuration & Dimensions :

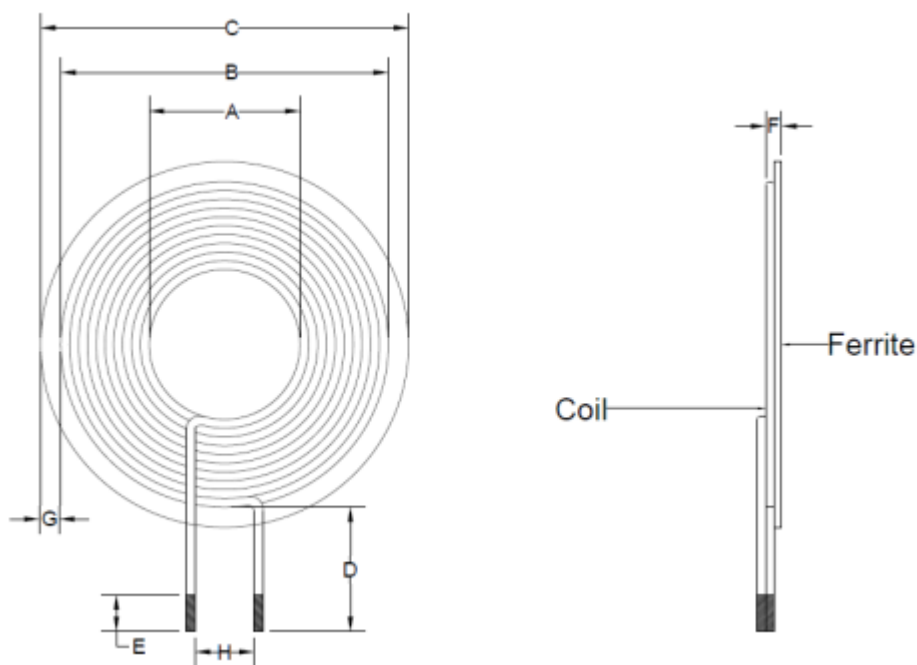

Unit: mm

| A | B | C | D | E | F | G | H |
|----------|----------|----------|----------|---------|---------|----------|----------|
| 20.5±0.5 | 44.0±1.5 | 50.0±0.5 | 17.0±1.0 | 5.0±1.0 | 2.4±0.5 | 2.0 Min. | 10.0 Typ |

3. Schematic



4. Electrical Characteristics

| Inductance (uH) | Test Frequency (Hz) | DCR Max. (mΩ) | Irms Max. (A) |
|--------------------|------------------------|------------------|------------------|
| 6.3±10% | 1V/100K | 45 | 5.0 |

5. General Specification:

- a) Operating Temp. : -25°C ~ +85°C
- b) Storage Temp. : -40°C ~ +85°C (on board)
- c) Irms: Base on temp. rise up to 40°C Max.