

### 1. PART NO. EXPRESSION :

S M C 1 0 0 8 R 1 5 M A F  
 (a) (b) (c) (d)(e)(f)

- (a) Series code
- (b) Dimension code
- (c) Inductance code : R15 = 0.15uH

- (d) Tolerance code : M = ±20%
- (e) A : Special Products
- (f) F : RoHS Compliant

### 2. CONFIGURATION & DIMENSIONS :

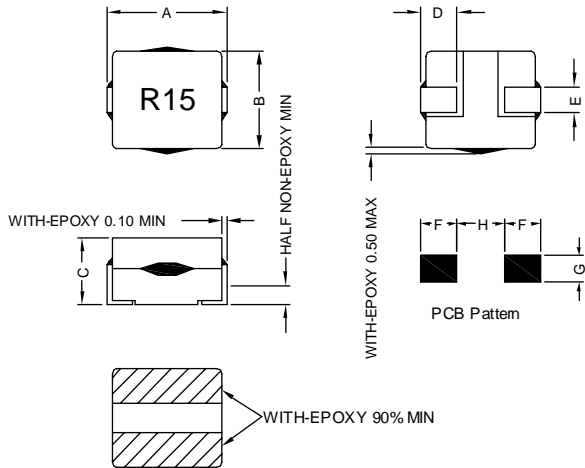

Unit : mm

A	B	C	D	E	F	G	H
10.4 Max.	8.00 Max.	7.00 Max.	2.54± 0.30	2.30± 0.20	3.29 Ref.	2.79 Ref.	4.32 Ref.

### 3. SCHEMATIC :

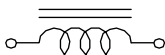

### 4. MATERIALS :

- a) Core
- b) Core
- c) Clip
- d) Adhesive

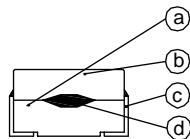

**RoHS Compliant**

NOTE : Specifications subject to change without notice. Please check our website for latest information.

05.01.2015



**SUPERWORLD ELECTRONICS (S) PTE LTD**

### 5. ELECTRICAL CHARACTERISTICS :

	SMC1008R15MAF	SMC1008R31MAF
a) $\Delta L / L_{0A}$	20% Max. at Isat	279nH Typ. at Isat
b) Temp. Rise	40° C Max. at Rated Current (I <sub>rms</sub> )	
c) Operating Temperature	-40° C ----+125° C	
d) Storage condition (component in its packaging)		
i) Temperature : -10 to 40° C		
ii) Humidity : 60%		

### 6. ELECTRICAL CHARACTERISTICS :

Part Number	Inductance ( uH )	Test Frequency ( Hz )	DC Resistance ( mΩ )	Isat ( A )	I <sub>rms</sub> ( A )
SMC1008R15MAF	0.15 ± 20%	1V/100K	0.41 ± 10%	70	70
SMC1008R31MAF	0.31 ± 20%	1V/100K	0.48 ± 8%	32	51



**RoHS Compliant**

NOTE : Specifications subject to change without notice. Please check our website for latest information.

05.01.2015



**SUPERWORLD ELECTRONICS (S) PTE LTD**

### 7. PACKAGING INFORMATION :

#### ( 1 ) CONFIGURATION

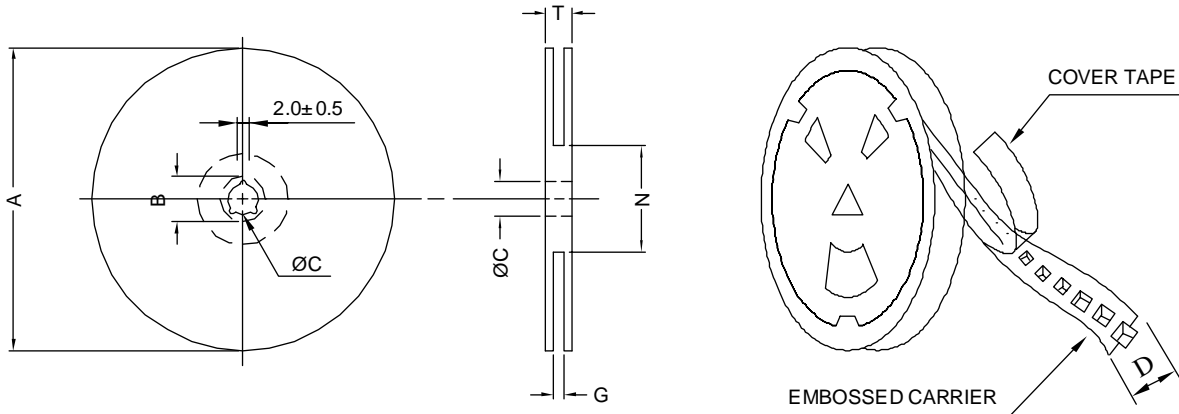

\* CARRIER TAPE WIDTH : D

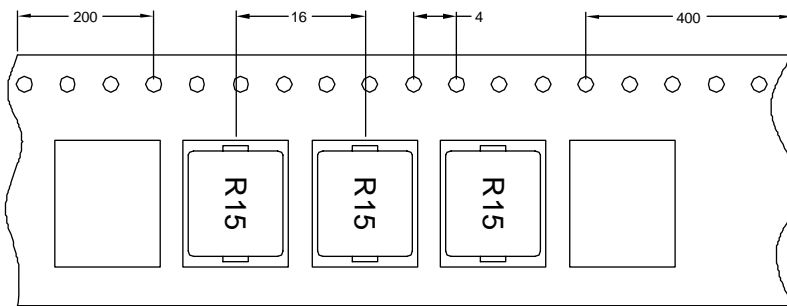

#### ( 2 ) DIMENSIONS

Unit:m/m

STYLE	A	B	C	D	G	N	T
13-24	330	21±0.8	13±0.5	24	26 <sup>+0</sup>	50 <sup>-0</sup>	30.4

#### ( 3 ) QTY & G.W. PER PACKAGE

SERIES	INNER : REEL			OUTER : CARTON		
	QTY (PCS)	G.W. (gw)	STYLE	QTY (PCS)	G.W. (Kg)	SIZE (cm)
SMC1008	500	1575	13-24	2000	7.3	38 x 36.5 x 21



**RoHS Compliant**

NOTE : Specifications subject to change without notice. Please check our website for latest information.

05.01.2015



**SUPERWORLD ELECTRONICS (S) PTE LTD**