

1. PART NO. EXPRESSION :

P I C 0 5 1 2 H P 1 R 0 M F - □ □
 (a) (b) (c) (d) (e)(f) (g)

- (a) Series code
- (b) Dimension code
- (c) Type code

- (d) Inductance code : 1R0 = 1.0uH
- (e) Tolerance code : M = ±20%, Y = ±30%
- (f) F : RoHS Compliant
- (g) 11~99 : Internal controlled number

2. CONFIGURATION & DIMENSIONS :

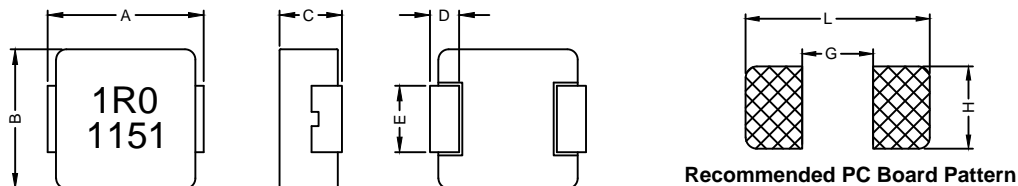

Unit:m/m

A	B	C	D	E	G	H	L
5.7±0.3	5.2±0.2	1.0±0.2	1.1±0.3	2.5±0.3	2.2	2.8	6.2

3. SCHEMATIC :

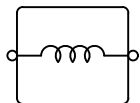

4. MATERIALS :

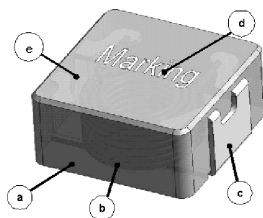

- (a) Core
- (b) Wire
- (c) Terminal
- (d) Ink
- (e) Paint



RoHS Compliant

NOTE : Specifications subject to change without notice. Please check our website for latest information.

05.11.2015

5. GENERAL SPECIFICATION :

- a) Test Freq. : L : 100KHz/1.0V
- b) Operating Temp. : -40°C to +125°C
- c) Storage Temp. : -40°C to +125°C
- d) Humidity Range : 85 ± 3% RH
- e) Heat Rated Current (Irms) will cause the coil temperature rise approximately Δt of 40°C (keep 1min)
- f) Saturation Current (Isat) will cause L0 to drop 20%.
- g) Part Temperature (Ambient+Temp. Rise) : Should not exceed 125°C under worst case operating conditions.
- h) Storage condition (component in its packaging)
 - i) Temperature: -10 to 40°C
 - ii) Humidity : 50-60% RH

6. ELECTRICAL CHARACTERISTICS :

Part No.	Inductance L ₀ (μH) @ 0 A	Irms (A) Typ.	Isat (A) Typ.	DCR (mΩ) Typ. @ 25°C	DCR (mΩ) Max. @ 25°C
PIC0512HPR10YF	0.10	14	14.5	4.3	5.2
PIC0512HPR22YF	0.22	10.7	14.0	5.5	6.7
PIC0512HPR33MF	0.33	8.5	13.5	7.8	9.4
PIC0512HPR36MF	0.36	8.0	13	10	11.5
PIC0512HPR47MF	0.47	7.0	11	13.6	15.8
PIC0512HPR68MF	0.68	6.0	9.0	21.5	24.5
PIC0512HP1R0MF	1.00	5.0	6.0	26	30
PIC0512HP1R2MF	1.20	4.5	5.5	33	40
PIC0512HP1R5MF	1.50	4.0	5.0	38	44
PIC0512HP2R2MF	2.20	3.5	4.0	65	75
PIC0512HP3R3MF	3.30	3.0	3.8	75	86
PIC0512HP4R7MF	4.70	2.5	3.2	100	115
PIC0512HP5R6MF	5.60	2.4	3.2	175	201
PIC0512HP6R8MF	6.80	2.0	3.0	193	222
PIC0512HP8R2MF	8.20	1.7	2.8	327	378
PIC0512HP100MF	10.0	1.5	1.8	335	385

Tolerance code : M = ±20%, Y = ±30%



RoHS Compliant

NOTE : Specifications subject to change without notice. Please check our website for latest information.

05.11.2015



SUPERWORLD ELECTRONICS (S) PTE LTD

PG. 2

7. CHARACTERISTICS CURVES :

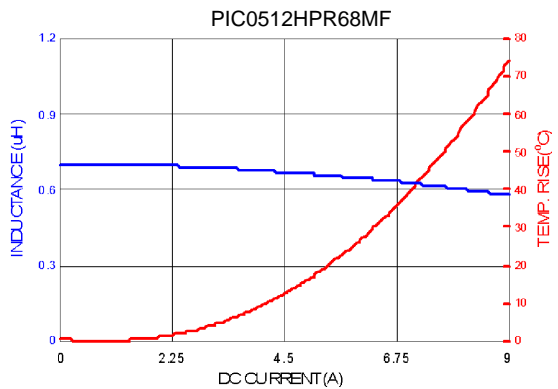
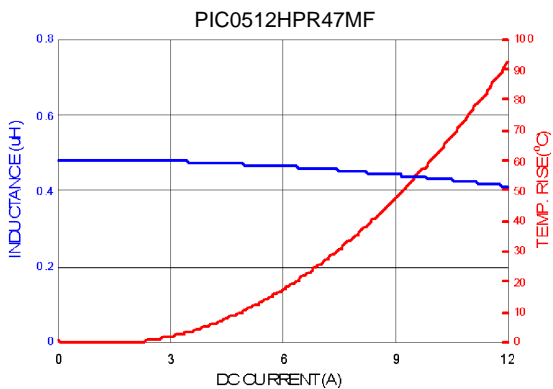
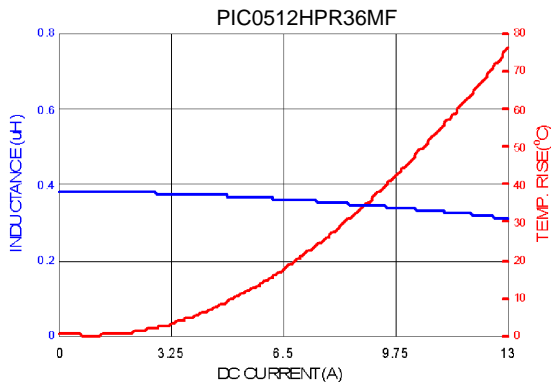
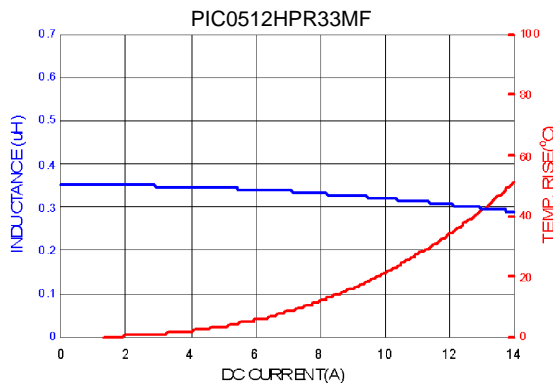
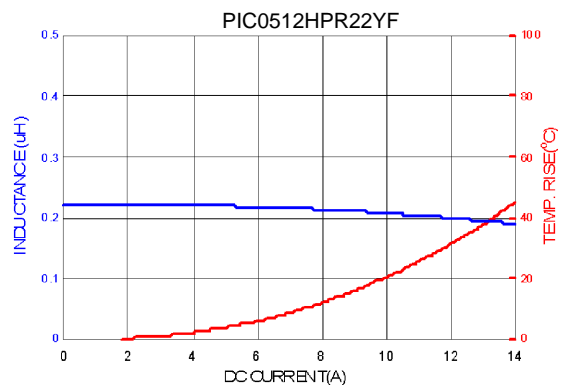
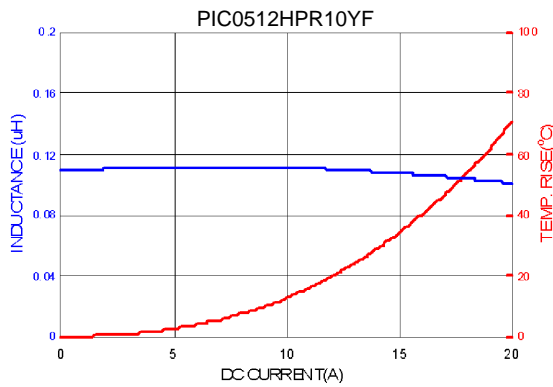

RoHS Compliant

NOTE : Specifications subject to change without notice. Please check our website for latest information.

05.11.2015



SUPERWORLD ELECTRONICS (S) PTE LTD

7. CHARACTERISTICS CURVES :

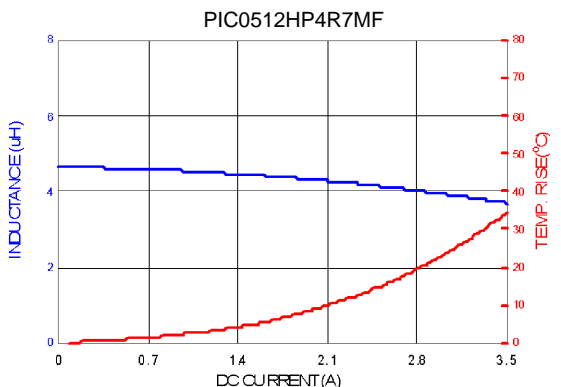
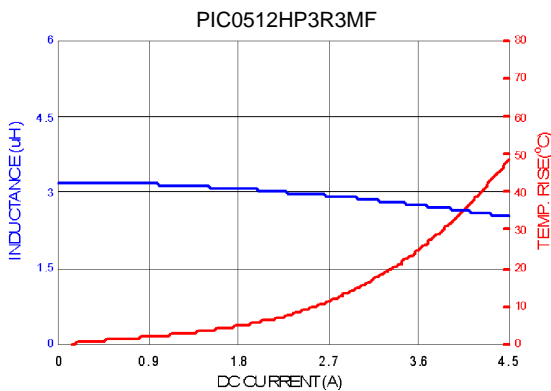
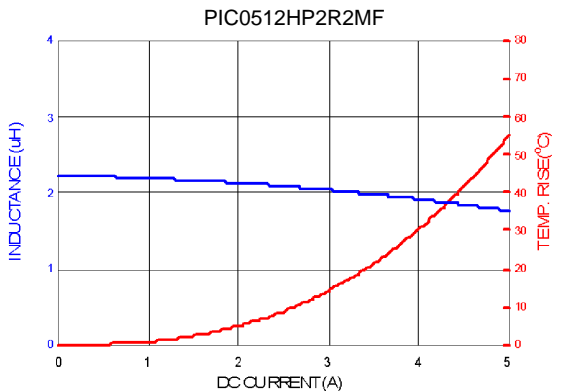
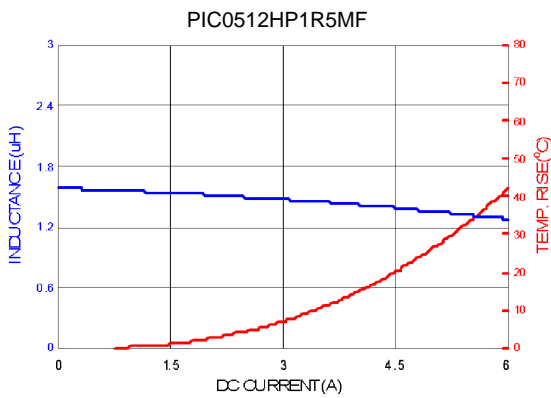
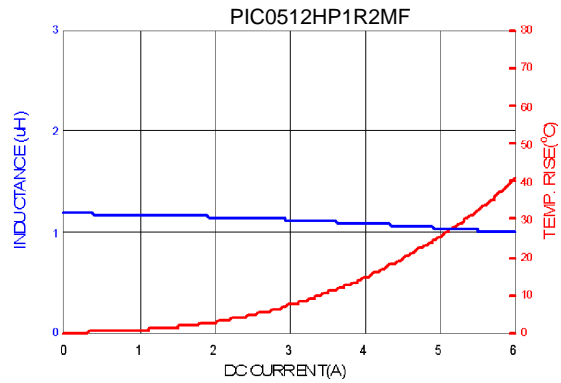
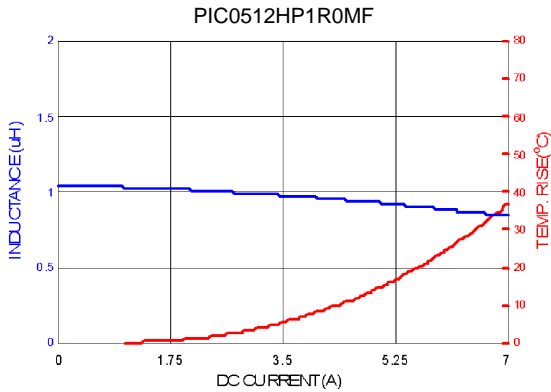

RoHS Compliant

NOTE : Specifications subject to change without notice. Please check our website for latest information.

05.11.2015



SUPERWORLD ELECTRONICS (S) PTE LTD

7. CHARACTERISTICS CURVES :

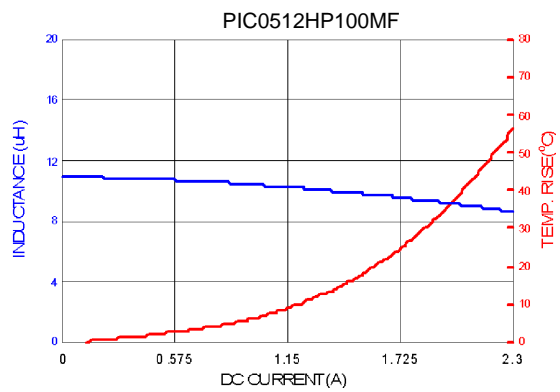
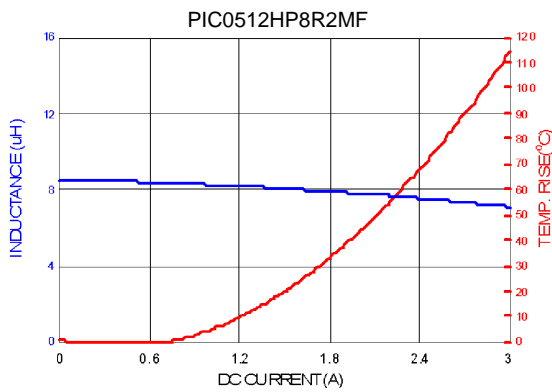
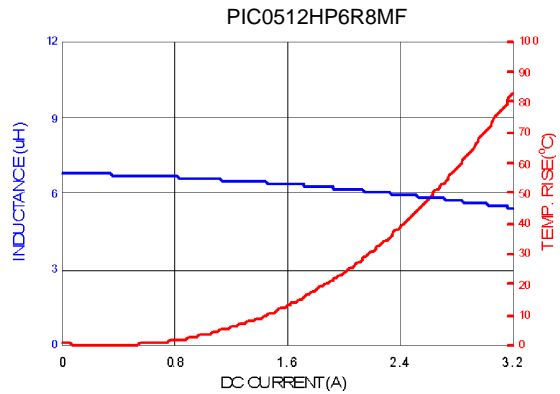
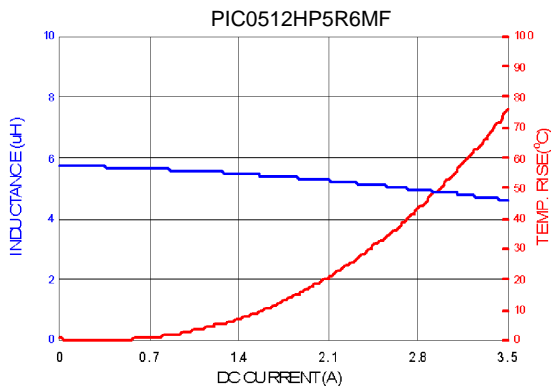

NOTE : Specifications subject to change without notice. Please check our website for latest information.



RoHS Compliant



8. SOLDERING :

Mildly activated rosin fluxes are preferred. The minimum amount of solder can lead to damage from the stresses caused by the difference in coefficients of expansion between solder, chip and substrate. Our terminations are suitable for all re-flow soldering systems. If hand soldering cannot be avoided, the preferred technique is the utilization of hot air soldering tools.

8-1.1 Solder Re-flow :

Recommended temperature profiles for re-flow soldering in Figure 1.

8-1.2 Soldering Iron (Figure 2) :

Products attachment with soldering iron is discouraged due to the inherent process control limitations. In the event that a soldering iron must be employed the following precautions are recommended.

Note :

- a) Preheat circuit and products to 150°C.
- b) 355°C tip temperature (max)
- c) Never contact the ceramic with the iron tip
- d) 1.0mm tip diameter (max)
- e) Use a 20 watt soldering iron with tip diameter of 1.0mm
- f) Limit soldering time to 4~5 secs.

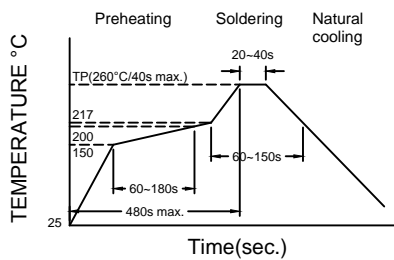

Figure 1. Re-flow Soldering: 3 times max.

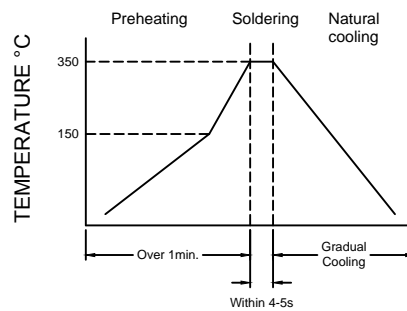

Figure 2. Hand Soldering: 1 times max.



RoHS Compliant

NOTE : Specifications subject to change without notice. Please check our website for latest information.

05.11.2015



SUPERWORLD ELECTRONICS (S) PTE LTD

9. PACKAGING INFORMATION :

9-1. Reel Dimension

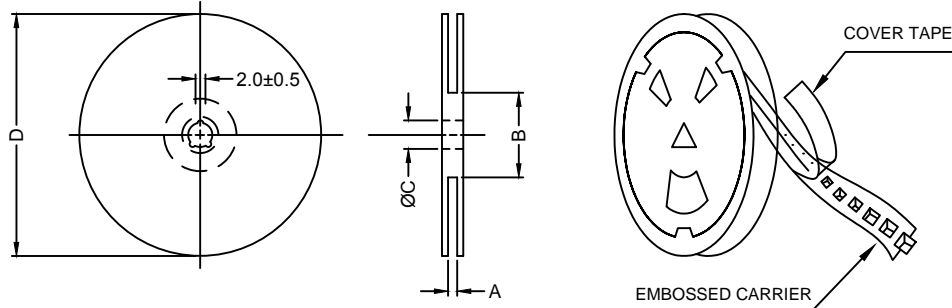

Type	A(mm)	B(mm)	C(mm)	D(mm)
13" x 12mm	12.4+2.0/-0	100±2.0	13.5±0.5	330

9-2. Tape Dimension

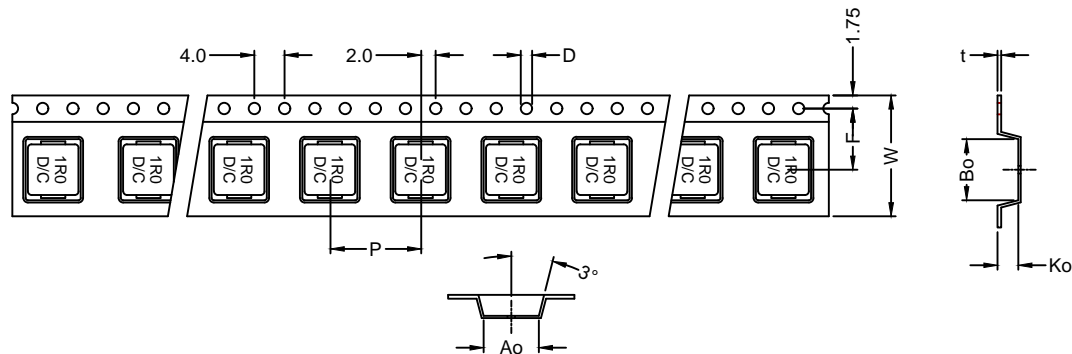

Series	Ao(mm)	Bo(mm)	Ko(mm)	P(mm)	W(mm)	F(mm)	t(mm)	D(mm)
PIC0512	5.5±0.1	6.2±0.1	1.5±0.1	8.0±0.1	12.0±0.3	5.5±0.1	0.35±0.05	1.5±0.1

9-3. Packaging Quantity

Size	PIC0512
Chip / Reel	4000
Inner Box	8000
Carton	32000



RoHS Compliant

NOTE : Specifications subject to change without notice. Please check our website for latest information.



9-4. Tearing Off Force

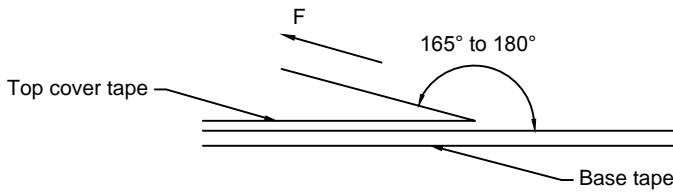

The force for tearing off cover tape is 10 to 130 grams in the arrow direction under the following conditions. (referenced ANSI/EIA-481-C-2003 of 4.11 standard)

Room Temp. (°C)	Room Humidity (%)	Room atm (hPa)	Tearing Speed (mm/min)
5~35	45~85	860~1060	300

Application Notice

1. Storage Conditions :

To maintain the solderability of terminal electrodes :

- Recommended products should be used within 12 months from the time of delivery.
- The packaging material should be kept where no chlorine or sulfur exists in the air.

2. Transportation :

- Products should be handled with care to avoid damage or contamination from perspiration and skin oils.
- Vacuum pick up is strongly recommended for individual components.
- Bulk handling should ensure that abrasion and mechanical shock are minimized.



RoHS Compliant

NOTE : Specifications subject to change without notice. Please check our website for latest information.

05.11.2015



SUPERWORLD ELECTRONICS (S) PTE LTD

PG. 8