

### 1. PART NO. EXPRESSION :

P I C 0 5 0 3 H P 1 R 0 M F - □ □  
 (a) (b) (c) (d) (e)(f) (g)

- (a) Series code
- (b) Dimension code
- (c) Type code

- (d) Inductance code : 1R0 = 1.0uH
- (e) Tolerance code : M = ±20%, Y = ±30%
- (f) F : RoHS Compliant
- (g) 11~99 : Internal controlled number

### 2. CONFIGURATION & DIMENSIONS :

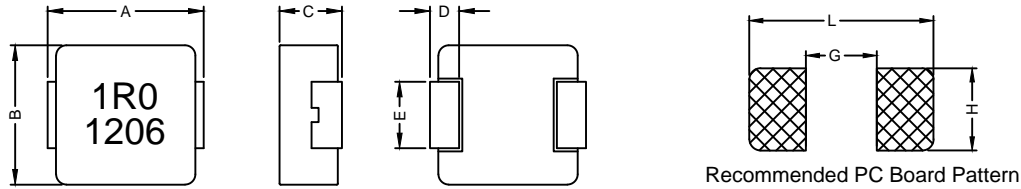

Unit:m/m

A	B	C	D	E	L	G	H
5.7±0.3	5.2±0.2	2.8±0.2	1.1±0.3	2.5±0.3	6.5	2.5	2.8

### 3. SCHEMATIC :

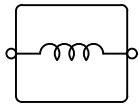

### 4. MATERIALS :

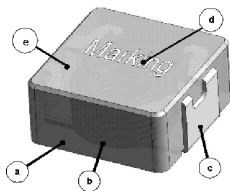

- (a) Core
- (b) Wire
- (c) Terminal
- (d) Ink
- (e) Paint



**RoHS Compliant**

NOTE : Specifications subject to change without notice. Please check our website for latest information.

05.11.2015

### 5. GENERAL SPECIFICATION :

- a) Test Freq. : L : 100KHz/1.0V
- b) Operating Temp. : -40°C to +125°C
- c) Storage Temp. : -40°C to +125°C
- d) Humidity Range : 85 ± 3% RH
- e) Heat Rated Current (Irms) will cause the coil temperature rise approximately  $\Delta t$  of 40°C (keep 1min)
- f) Saturation Current (Isat) will cause L0 to drop 20%.
- g) Part Temperature (Ambient+Temp. Rise) : Should not exceed 125°C under worst case operating conditions.
- h) Storage condition (component in its packaging)
  - i) Temperature: -10 to 40°C
  - ii) Humidity : 50~60% RH

### 6. ELECTRICAL CHARACTERISTICS :

Part No.	Inductance L <sub>0</sub> ( $\mu$ H) @ 0 A	Irms ( A ) Typ.	Isat ( A ) Typ.	DCR ( m $\Omega$ ) Typ. @ 25°C	DCR ( m $\Omega$ ) Max. @ 25°C
PIC0503HPR10YF	0.10	23	27	2.5	3.0
PIC0503HPR22MF	0.22	15.5	21	3.7	4.4
PIC0503HPR33MF	0.33	13.7	19	4.5	5.2
PIC0503HPR47MF	0.47	12.2	16	6.7	7.1
PIC0503HPR68MF	0.68	10.2	13.5	8.2	9.0
PIC0503HPR82MF	0.82	9.3	13	10.2	11.9
PIC0503HP1R0MF	1.00	8.8	12	12.6	13.7
PIC0503HP1R5MF	1.50	7.2	11	18.7	20.7
PIC0503HP2R2MF	2.20	5.8	10	25	29.2
PIC0503HP3R3MF	3.30	5.0	8.5	41	49.2
PIC0503HP4R7MF	4.70	3.5	8.2	71	77.5
PIC0503HP5R6MF	5.60	3.0	7.0	88.5	102
PIC0503HP6R8MF	6.80	2.8	6.0	96	112
PIC0503HP8R2MF	8.20	2.6	4.5	99	114
PIC0503HP100MF	10.0	2.5	4.0	112	130
PIC0503HP150MF	15.0	1.9	2.5	210	242

Tolerance code : M =  $\pm 20\%$ , Y =  $\pm 30\%$



**RoHS Compliant**

NOTE : Specifications subject to change without notice. Please check our website for latest information.

05.11.2015

### 7. CHARACTERISTICS CURVES :

PIC0503HPR10YF

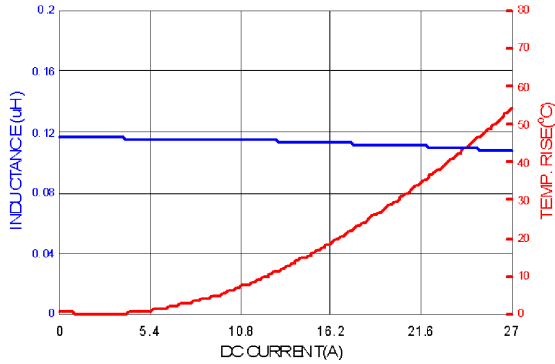

PIC0503HPR22MF

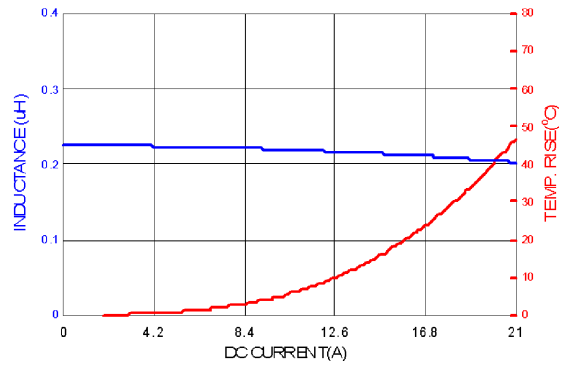

PIC0503HPR33MF

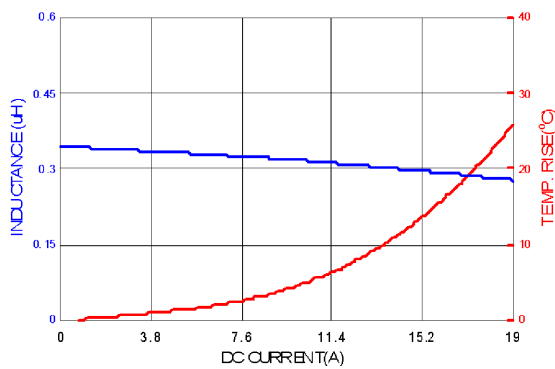

PIC0503HPR47MF

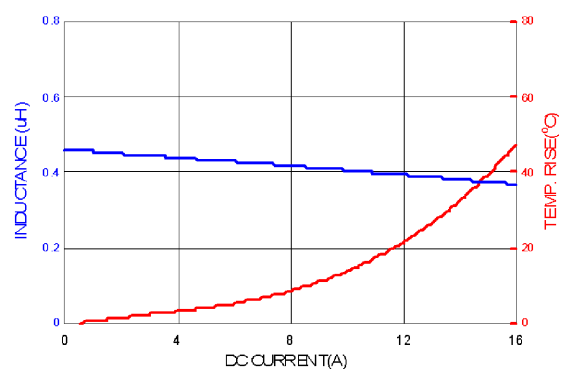

PIC0503HPR68MF

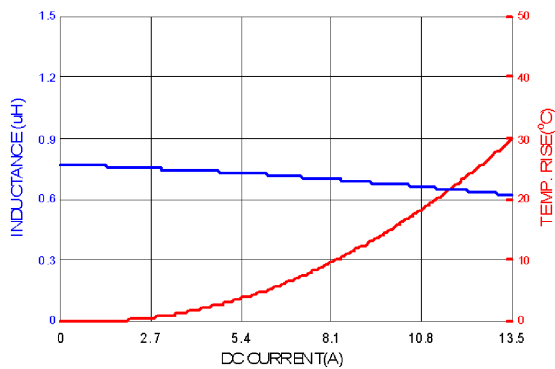

PIC0503HPR82MF

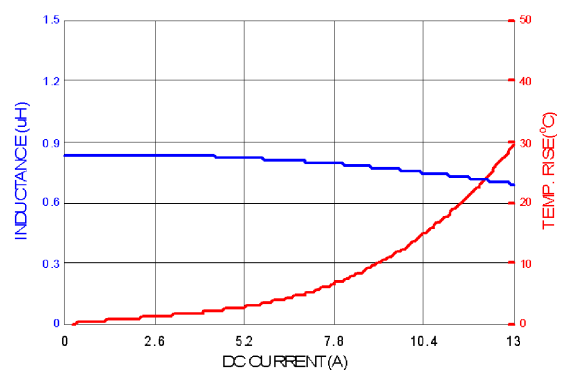

**RoHS Compliant**

NOTE : Specifications subject to change without notice. Please check our website for latest information.

05.11.2015



**SUPERWORLD ELECTRONICS (S) PTE LTD**

### 7. CHARACTERISTICS CURVES :

PIC0503HP1R0MF

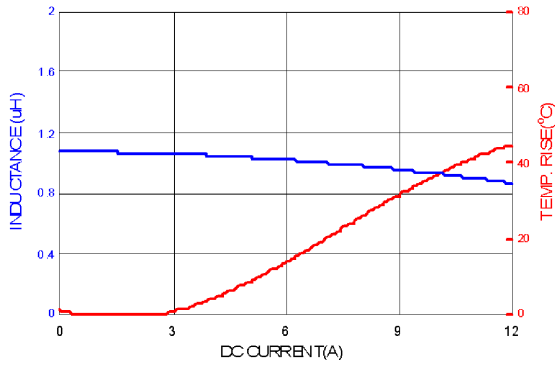

PIC0503HP1R5MF

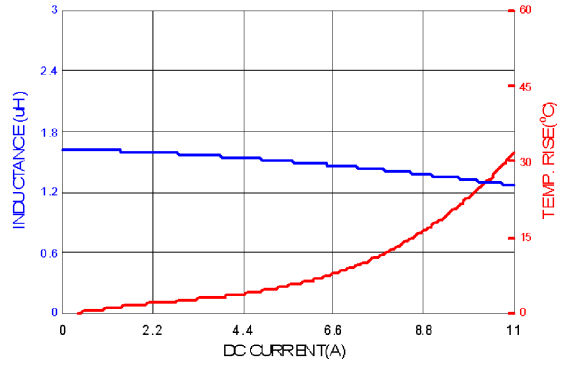

PIC0503HP2R2MF

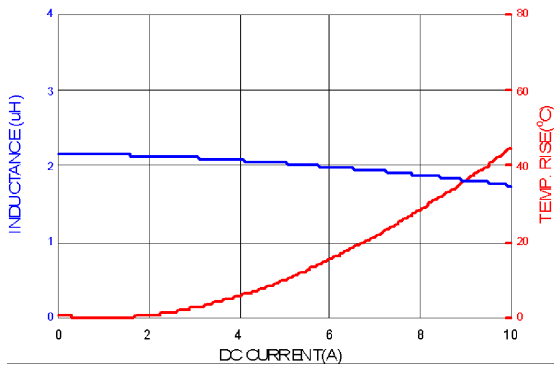

PIC0503HP3R3MF

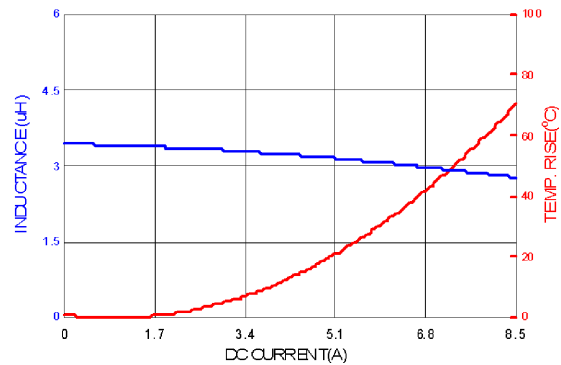

PIC0503HP4R7MF

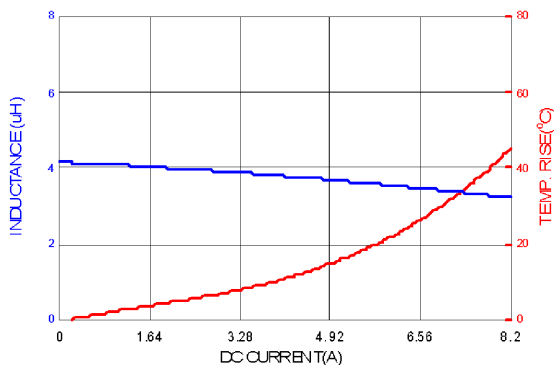

PIC0503HP5R6MF

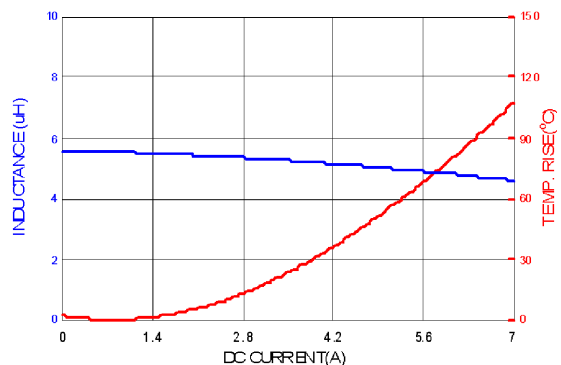

**RoHS Compliant**

NOTE : Specifications subject to change without notice. Please check our website for latest information.

05.11.2015



**SUPERWORLD ELECTRONICS (S) PTE LTD**

### 7. CHARACTERISTICS CURVES :

PIC0503HP6R8MF

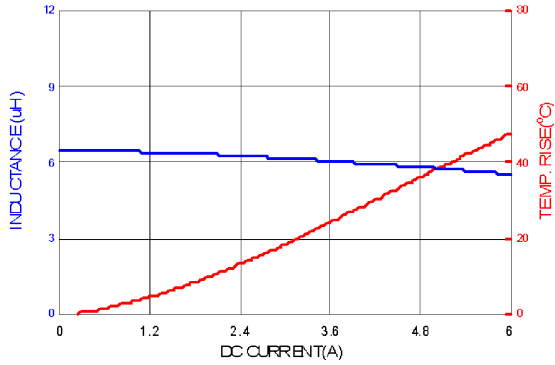

PIC0503HP8R2MF

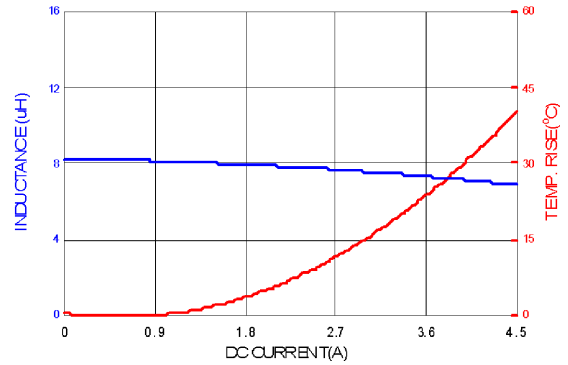

PIC0503HP100MF

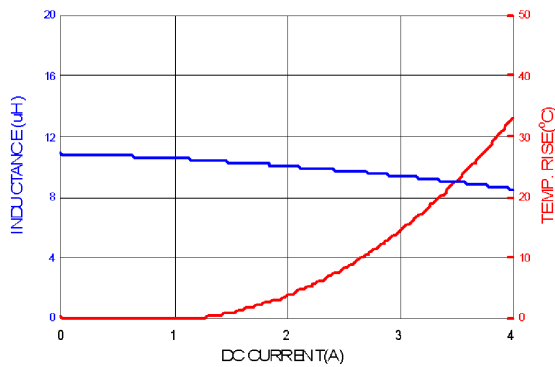

PIC0503HP150MF

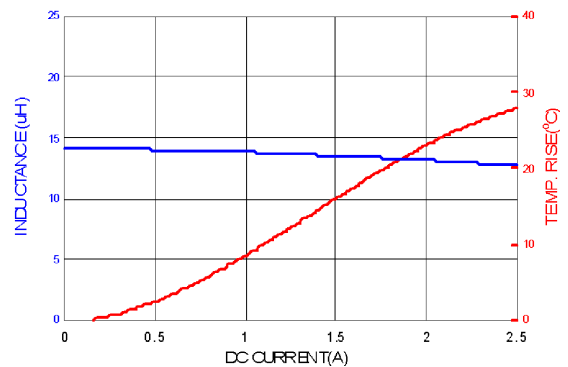

**RoHS Compliant**

NOTE : Specifications subject to change without notice. Please check our website for latest information.

05.11.2015



**SUPERWORLD ELECTRONICS (S) PTE LTD**

## 8. SOLDERING :

Mildly activated rosin fluxes are preferred. The minimum amount of solder can lead to damage from the stresses caused by the difference in coefficients of expansion between solder, chip and substrate. Our terminations are suitable for all re-flow soldering systems. If hand soldering cannot be avoided, the preferred technique is the utilization of hot air soldering tools.

### 8-1.1 Solder Re-flow :

Recommended temperature profiles for re-flow soldering in Figure 1.

### 8-1.2 Soldering Iron (Figure 2) :

Products attachment with soldering iron is discouraged due to the inherent process control limitations. In the event that a soldering iron must be employed the following precautions are recommended.

Note :

- Preheat circuit and products to 150°C.
- 355°C tip temperature (max)
- Never contact the ceramic with the iron tip
- 1.0mm tip diameter (max)
- Use a 20 watt soldering iron with tip diameter of 1.0mm
- Limit soldering time to 4~5 secs.

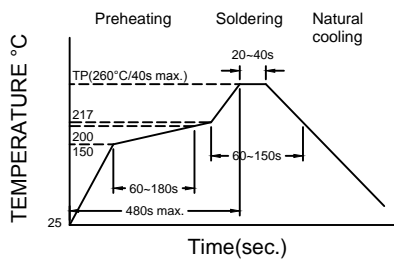

Figure 1. Re-flow Soldering: 3 times max.

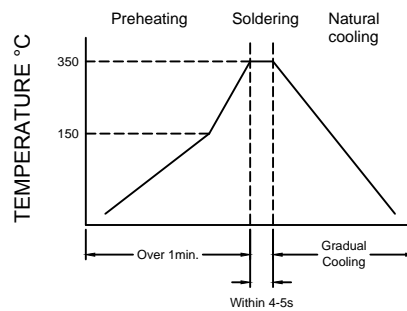

Figure 2. Hand Soldering: 1 times max.



**RoHS Compliant**

NOTE : Specifications subject to change without notice. Please check our website for latest information.

05.11.2015



**SUPERWORLD ELECTRONICS (S) PTE LTD**

### 9. PACKAGING INFORMATION :

#### 9-1. Reel Dimension

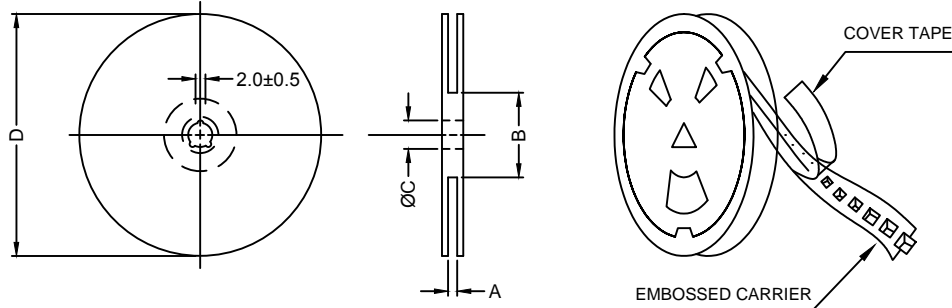

Type	A(mm)	B(mm)	C(mm)	D(mm)
13" x 12mm	12.4+2.0/-0	100±2.0	13.5±0.5	330

#### 9-2. Tape Dimension

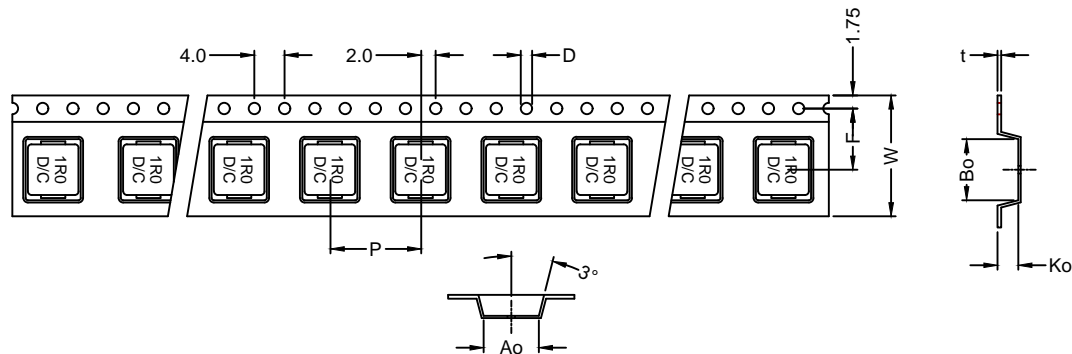

Series	Ao(mm)	Bo(mm)	Ko(mm)	P(mm)	W(mm)	F(mm)	t(mm)	D(mm)
PIC0503HP	5.5±0.1	6.2±0.1	3.3±0.1	8.0±0.1	12.0±0.3	5.5±0.1	0.35±0.05	1.5±0.1

#### 9-3. Packaging Quantity

Size	PIC0503HP
Chip / Reel	2000
Inner Box	4000
Carton	16000



**RoHS Compliant**

NOTE : Specifications subject to change without notice. Please check our website for latest information.

### 9-4. Tearing Off Force

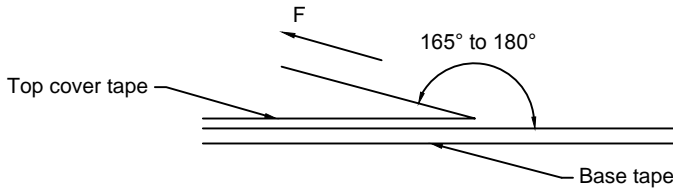

The force for tearing off cover tape is 10 to 130 grams in the arrow direction under the following conditions. (referenced ANSI/EIA-481-C-2003 of 4.11 standard)

Room Temp. (°C)	Room Humidity (%)	Room atm (hPa)	Tearing Speed (mm/min)
5~35	45~85	860~1060	300

### Application Notice

#### 1. Storage Conditions :

To maintain the solderability of terminal electrodes :

- a) Recommended products should be used within 12 months from the time of delivery.
- b) The packaging material should be kept where no chlorine or sulfur exists in the air.

#### 2. Transportation :

- a) Products should be handled with care to avoid damage or contamination from perspiration and skin oils.
- b) Vacuum pick up is strongly recommended for individual components.
- c) Bulk handling should ensure that abrasion and mechanical shock are minimized.



**RoHS Compliant**

NOTE : Specifications subject to change without notice. Please check our website for latest information.

05.11.2015



**SUPERWORLD ELECTRONICS (S) PTE LTD**