

FEATURES

- SURFACE MOUNTABLE 0805, 1206, 2010 AND 2512 CASE SIZE
- LOW RESISTANCE METAL STRIP CONSTRUCTION
- PRECISION TOLERANCE ($\pm 1\%$)
- TAPED & REEL PACKAGING FOR EASY PICK AND PLACE
- REFLOW COMPATIBLE

**RoHS
Compliant**
includes all homogeneous materials

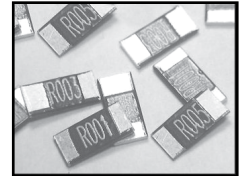

See Part Number System for Details

SPECIFICATIONS

Type	EIA Size	Material (See Note on EMF Characteristics Below)	Power Rating at 70°C	Resistance Tolerance (Code)	Temperature Coefficient (ppm/°C, +25°C ~ +125°C)	Resistance Range*	Operating Temperature Range (°C)	
NCSS10	0805	Mn-Cu	1/8W (B)	$\pm 1\%$ (F) $\pm 2\%$ (G) $\pm 5\%$ (J)	± 100 ppm	5m Ω ~ 25m Ω	-55°C ~ +170°C	
			1/4W (A)					
			1/2W (S)					
NCSS12	1206	Mn-Cu	1/4W (A)			1m Ω = ± 200 ppm 2m Ω ~ 10m Ω = ± 100 ppm >10m Ω = ± 75 ppm		1m Ω ~ 30m Ω
			1/2W (S)					
			1W (C)					
NCSS20	2010	Ni-Cu	1/2W (S)			5m Ω ~ 10m Ω = ± 100 ppm >10m Ω = ± 75 ppm		5m Ω ~ 50m Ω
			3/4W (I)					
			1W (C)					
			1.5W (D)					
NCSS25	2512	Ni-Cu	1W (C)	1m Ω = ± 275 ppm 2m Ω ~ 10m Ω = ± 100 ppm >10m Ω = ± 75 ppm	1m Ω ~ 50m Ω			
			1.5W (D)		1m Ω ~ 15m Ω			
			2W (E)		1m Ω ~ 10m Ω			
NCSS25	2512	Mn-Cu	1W (C)	1.5m Ω ~ 10m Ω = ± 100 ppm >10m Ω = ± 75 ppm	1.5m Ω ~ 50m Ω			
			1.5W (D)					
			2W (E)					

*Contact NIC regarding availability of values not shown

PART NUMBER SYSTEM

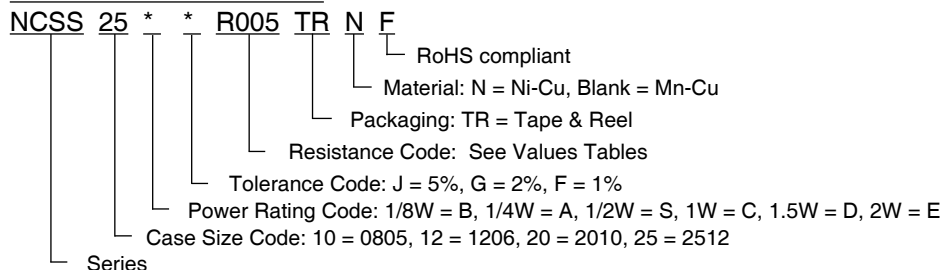

*Insert appropriate power rating and tolerance codes,
Contact NIC regarding availability of other values

THERMAL EMF CHARACTERISTICS:

Standard Mn-Cu Construction: Thermal EMF = -1 μ V/°C

Low Cost Ni-Cu Construction: Thermal EMF = -40 μ V/°C

RATED CURRENT: $I = \sqrt{P/R}$

EXAMPLE: Part Number NCSS25E_R001TRNF

P = 2W

R = 0.001W (1milli-ohm)

$I = \sqrt{P/R} = \sqrt{2/0.001} = 44.7A$



ENVIRONMENTAL CHARACTERISTICS

Item	Specification				Test Method	Reference Standard
	0805	1206	2010	2512		
Temperature Coefficient of Resistance	Within specified value				+25°C ~ +125°C	IEC60115-1 4.8 JIS-C5201 4.8
Load Life	<±1%	<±1%	<±1%	<±1%	1,000 hours at rated power, +70°C, 1.5 hours ON, 0.5 hours OFF	IEC60115-1 4.25.1 JIS-C5201 4.25.1
Short Time Overload	<±0.5%	<±0.5%	<±0.5%	<±0.5%	5 x rated power for 5 seconds	IEC60115-1 4.13 JIS-C5201 4.13
Moisture Resistance (no load)	<±1%	<±1.0%	<±1%	<±1%	+85°C, 85% RH, 1000 hours	IEC60115-1 4.24.2 1a JIS-C5201 4.24.2 1a
Temperature Cycling	<±0.5%	<±0.5%	<±0.5%	<±0.5%	-55°C & +155°C, 300 cycles, 15 minutes at each temperature	IEC60115-1 4.19 JIS-C5201 4.19
Resistance to Soldering Heat	<±0.5%	<±0.5%	<±0.5%	<±0.5%	+260°C ± 5°C for 10 sec. ±1 sec., Two cycles (20 sec. ±1 sec. for 2512 size)	IEC60115-1 4.18 JIS-C5201 4.18
Solderability	At least 95% coverage of electrode surface				+245°C ± 5°C, 2 sec. ± 0.5sec.	IEC60115-1 4.17 JIS-C5201 4.17
High Temperature Exposure	<±1%	<±1%	<±1%	<±1%	+170°C for 1,000 hours	IEC60115-1 4.23.2 JIS-C5201 4.23.2
Low Temperature Storage	<±0.5%	<±0.5%	<±0.5%	<±0.5%	-55°C for 1,000 hours	IEC60115-1 4.23.4 JIS-C5201 4.23.4
Substrate Bending	<±1%	<±0.5%	<±0.5%	<±0.5%	Bending within 2mm	IEC60115-1 4.33 JIS-C5201 4.33
Insulation Resistance	>100MΩ				100VDC for 1 minute	IEC60115-1 4.6 JIS-C5201 4.6

Power Derating Curve: For operation above 70°C, power rating must be derated according to the following chart:

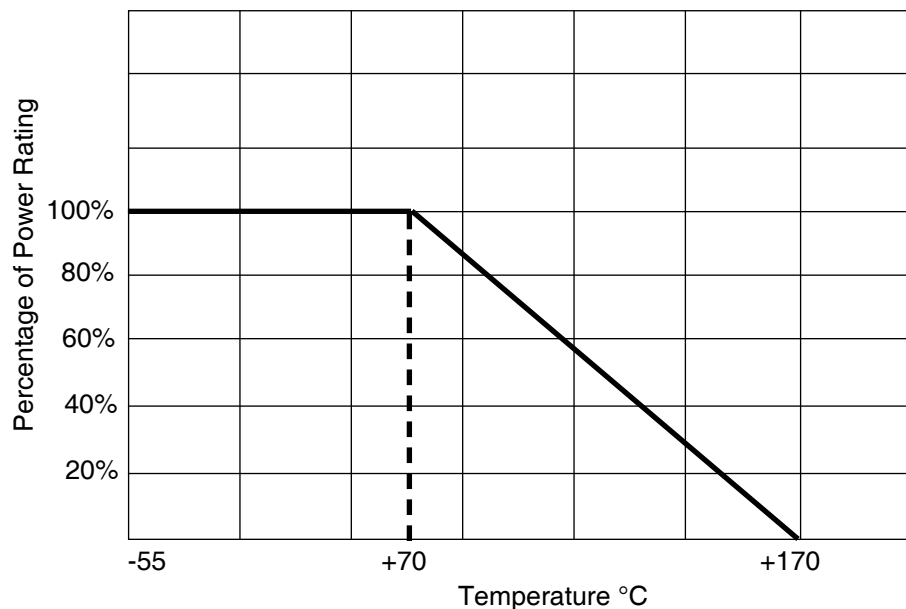

NCSS10 (0805 CASE SIZE 1/8W, 1/4W and 1/2W) AVAILABLE VALUES (Mn-Cu)

Part Number	Resistance Value (mΩ)	Available Power Ratings	Available Tolerance	Available TCR
NCSS10__R005TRF	5.0	1/8W (B), 1/4W (A), 1/2W (S)	±1% (F), ±2% (G), ±5% (J)	±100ppm
NCSS10__R006TRF	6.0	1/8W (B), 1/4W (A), 1/2W (S)	±1% (F), ±2% (G), ±5% (J)	±100ppm
NCSS10__R008TRF	8.0	1/8W (B), 1/4W (A), 1/2W (S)	±1% (F), ±2% (G), ±5% (J)	±100ppm
NCSS10__R009TRF	9.0	1/8W (B), 1/4W (A), 1/2W (S)	±1% (F), ±2% (G), ±5% (J)	±100ppm
NCSS10__R010TRF	10	1/8W (B), 1/4W (A), 1/2W (S)	±1% (F), ±2% (G), ±5% (J)	±100ppm
NCSS10__R020TRF	20	1/8W (B), 1/4W (A), 1/2W (S)	±1% (F), ±2% (G), ±5% (J)	±100ppm
NCSS10__R025TRF	25	1/8W (B), 1/4W (A), 1/2W (S)	±1% (F), ±2% (G), ±5% (J)	±100ppm

NCSS12 (1206 CASE SIZE 1/4W, 1/2W AND 1W) AVAILABLE VALUES (Mn-Cu)

Part Number	Resistance Value (mΩ)	Available Power Ratings	Available Tolerance	Available TCR
NCSS12__R001TRF	1.0	1/4W (A), 1/2W (S), 1W (C)	±1% (F), ±2% (G), ±5% (J)	±200ppm
NCSS12__R002TRF	2.0	1/4W (A), 1/2W (S), 1W (C)	±1% (F), ±2% (G), ±5% (J)	±100ppm
NCSS12__R003TRF	3.0	1/4W (A), 1/2W (S), 1W (C)	±1% (F), ±2% (G), ±5% (J)	±100ppm
NCSS12__R004TRF	4.0	1/4W (A), 1/2W (S), 1W (C)	±1% (F), ±2% (G), ±5% (J)	±100ppm
NCSS12__R005TRF	5.0	1/4W (A), 1/2W (S), 1W (C)	±1% (F), ±2% (G), ±5% (J)	±100ppm
NCSS12__R006TRF	6.0	1/4W (A), 1/2W (S), 1W (C)	±1% (F), ±2% (G), ±5% (J)	±100ppm
NCSS12__R007TRF	7.0	1/4W (A), 1/2W (S), 1W (C)	±1% (F), ±2% (G), ±5% (J)	±100ppm
NCSS12__R008TRF	8.0	1/4W (A), 1/2W (S), 1W (C)	±1% (F), ±2% (G), ±5% (J)	±100ppm
NCSS12__R009TRF	9.0	1/4W (A), 1/2W (S), 1W (C)	±1% (F), ±2% (G), ±5% (J)	±100ppm
NCSS12__R010TRF	10	1/4W (A), 1/2W (S), 1W (C)	±1% (F), ±2% (G), ±5% (J)	±100ppm
NCSS12__R012TRF	12	1/4W (A), 1/2W (S), 1W (C)	±1% (F), ±2% (G), ±5% (J)	±75ppm
NCSS12__R014TRF	14	1/4W (A), 1/2W (S), 1W (C)	±1% (F), ±2% (G), ±5% (J)	±75ppm
NCSS12__R015TRF	15	1/4W (A), 1/2W (S), 1W (C)	±1% (F), ±2% (G), ±5% (J)	±75ppm
NCSS12__R020TRF	20	1/4W (A), 1/2W (S), 1W (C)	±1% (F), ±2% (G), ±5% (J)	±75ppm
NCSS12__R022TRF	22	1/4W (A), 1/2W (S), 1W (C)	±1% (F), ±2% (G), ±5% (J)	±75ppm
NCSS12__R025TRF	25	1/4W (A), 1/2W (S), 1W (C)	±1% (F), ±2% (G), ±5% (J)	±75ppm
NCSS12__R030TRF	30	1/4W (A), 1/2W (S), 1W (C)	±1% (F), ±2% (G), ±5% (J)	±75ppm

NCSS20 (2010 CASE SIZE 1/2W, 3/4W, 1W and 1.5W) AVAILABLE VALUES (Ni-Cu)

Part Number	Resistance Value (mΩ)	Available Power Ratings	Available Tolerance	Available TCR
NCSS20__R005TRNF	5.0	1/2W (S), 3/4W (I), 1W (C), 1.5W (D)	±1% (F), ±2% (G), ±5% (J)	±100ppm
NCSS20__R006TRNF	6.0	1/2W (S), 3/4W (I), 1W (C), 1.5W (D)	±1% (F), ±2% (G), ±5% (J)	±100ppm
NCSS20__R010TRNF	10	1/2W (S), 3/4W (I), 1W (C), 1.5W (D)	±1% (F), ±2% (G), ±5% (J)	±100ppm
NCSS20__R015TRNF	15	1/2W (S), 3/4W (I), 1W (C), 1.5W (D)	±1% (F), ±2% (G), ±5% (J)	±75ppm
NCSS20__R020TRNF	20	1/2W (S), 3/4W (I), 1W (C), 1.5W (D)	±1% (F), ±2% (G), ±5% (J)	±75ppm
NCSS20__R022TRNF	22	1/2W (S), 3/4W (I), 1W (C), 1.5W (D)	±1% (F), ±2% (G), ±5% (J)	±75ppm
NCSS20__R024TRNF	24	1/2W (S), 3/4W (I), 1W (C), 1.5W (D)	±1% (F), ±2% (G), ±5% (J)	±75ppm
NCSS20__R030TRNF	30	1/2W (S), 3/4W (I), 1W (C), 1.5W (D)	±1% (F), ±2% (G), ±5% (J)	±75ppm
NCSS20__R050TRNF	50	1/2W (S), 3/4W (I), 1W (C), 1.5W (D)	±1% (F), ±2% (G), ±5% (J)	±75ppm

NCSS25 (2512 CASE SIZE 1W, 1.5W and 2W) AVAILABLE VALUES (Ni-Cu)

Part Number	Resistance Value (mΩ)	Available Power Ratings	Available Tolerance	Available TCR
NCSS25__R001TRNF	1.0	1W (C), 1.5W (D), 2W (E)	±1% (F), ±2% (G), ±5% (J)	±275ppm
NCSS25__R002TRNF	2.0	1W (C), 1.5W (D), 2W (E)	±1% (F), ±2% (G), ±5% (J)	±100ppm
NCSS25__R003TRNF	3.0	1W (C), 1.5W (D), 2W (E)	±1% (F), ±2% (G), ±5% (J)	±100ppm
NCSS25__R004TRNF	4.0	1W (C), 1.5W (D), 2W (E)	±1% (F), ±2% (G), ±5% (J)	±100ppm
NCSS25__R005TRNF	5.0	1W (C), 1.5W (D), 2W (E)	±1% (F), ±2% (G), ±5% (J)	±100ppm
NCSS25__R006TRNF	6.0	1W (C), 1.5W (D), 2W (E)	±1% (F), ±2% (G), ±5% (J)	±100ppm
NCSS25__R007TRNF	7.0	1W (C), 1.5W (D), 2W (E)	±1% (F), ±2% (G), ±5% (J)	±100ppm
NCSS25__R008TRNF	8.0	1W (C), 1.5W (D), 2W (E)	±1% (F), ±2% (G), ±5% (J)	±100ppm
NCSS25__R010TRNF	10	1W (C), 1.5W (D), 2W (E)	±1% (F), ±2% (G), ±5% (J)	±100ppm
NCSS25__R011TRNF	11	1W (C), 1.5W (D)	±1% (F), ±2% (G), ±5% (J)	±75ppm
NCSS25__R012TRNF	12	1W (C), 1.5W (D)	±1% (F), ±2% (G), ±5% (J)	±75ppm
NCSS25__R015TRNF	15	1W (C), 1.5W (D)	±1% (F), ±2% (G), ±5% (J)	±75ppm
NCSS25C_R018TRNF	18	1W (C)	±1% (F), ±2% (G), ±5% (J)	±75ppm
NCSS25C_R020TRNF	20	1W (C)	±1% (F), ±2% (G), ±5% (J)	±75ppm
NCSS25C_R025TRNF	25	1W (C)	±1% (F), ±2% (G), ±5% (J)	±75ppm
NCSS25C_R030TRNF	30	1W (C)	±1% (F), ±2% (G), ±5% (J)	±75ppm
NCSS25C_R033TRNF	33	1W (C)	±1% (F), ±2% (G), ±5% (J)	±75ppm
NCSS25C_R035TRNF	35	1W (C)	±1% (F), ±2% (G), ±5% (J)	±75ppm
NCSS25C_R040TRNF	40	1W (C)	±1% (F), ±2% (G), ±5% (J)	±75ppm
NCSS25C_R050TRNF	50	1W (C)	±1% (F), ±2% (G), ±5% (J)	±75ppm

NCSS25 (1W, 1.5W and 2W 2512 CASE SIZE) AVAILABLE VALUES (Mn-Cu)

Part Number	Resistance Value (mΩ)	Available Power Ratings	Available Tolerance	Available TCR
NCSS25__R0015TRF	1.5	1W (C), 1.5W (D), 2W (E)	±1% (F), ±2% (G), ±5% (J)	±100
NCSS25__R005TRF	5.0	1W (C), 1.5W (D), 2W (E)	±1% (F), ±2% (G), ±5% (J)	±100
NCSS25__R010TRF	10	1W (C), 1.5W (D), 2W (E)	±1% (F), ±2% (G), ±5% (J)	±100
NCSS25C_R020TRF	20	1W (C)	±1% (F), ±2% (G), ±5% (J)	±75ppm
NCSS25C_R025TRF	25	1W (C)	±1% (F), ±2% (G), ±5% (J)	±75ppm
NCSS25C_R030TRF	30	1W (C)	±1% (F), ±2% (G), ±5% (J)	±75ppm
NCSS25C_R040TRF	40	1W (C)	±1% (F), ±2% (G), ±5% (J)	±75ppm
NCSS25C_R050TRF	50	1W (C)	±1% (F), ±2% (G), ±5% (J)	±75ppm

COMPONENT DIMENSIONS AND PART MARKING

Case Size	L	W	T	P
0805	2.0 ± 0.1	1.25 ± 0.1	0.6 ± 0.2	0.4 ± 0.2

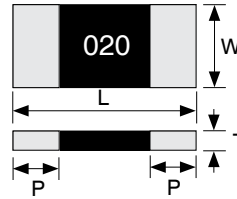

Case Size	L	W	T	P
1206	3.2 ± 0.2	1.6 ± 0.2	$1\text{m}\Omega = 0.75 \pm 0.2$ $2\text{m}\Omega \sim 30\text{m}\Omega = 0.6 \pm 0.2$	$1\text{m}\Omega = 1.1 \pm 0.3$ $2\text{m}\Omega \sim 30\text{m}\Omega = 0.5 \pm 0.3$
2010	5.0 ± 0.2	2.5 ± 0.2	0.6 ± 0.2	0.6 ± 0.3

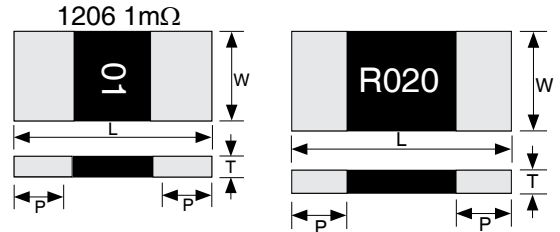

Case Size	L	W	T	P
2512	6.4 ± 0.2	3.2 ± 0.2	0.6 ± 0.2	$R \leq 3\text{m}\Omega = 2.0 \pm 0.2$
				$R > 3\text{m}\Omega = 0.9 \pm 0.2$

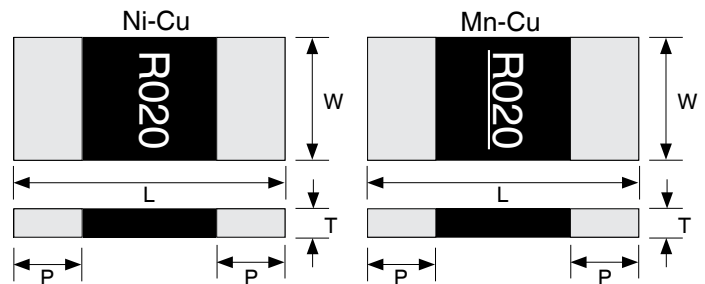

RECOMMENDED LAND PATTERN DIM. (mm)

Case Size	A	B	C
0805	1.2	3.5	1.4

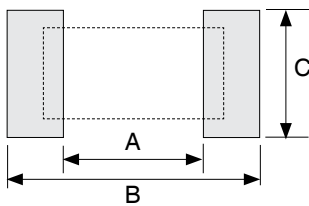

RECOMMENDED LAND PATTERN DIM. (mm)

Case Size	A	B	C
1206	$1\text{m}\Omega = 1.0$	2.3	1.8
	$2\text{m}\Omega \sim 30\text{m}\Omega = 1.6$	1.7	1.8
2010	3.5	1.5	3.4
2512	$1\text{m}\Omega \sim 3\text{m}\Omega = 1.3$	3.1	4.0
	$4\text{m}\Omega \sim 50\text{m}\Omega = 4.1$	2.1	4.0

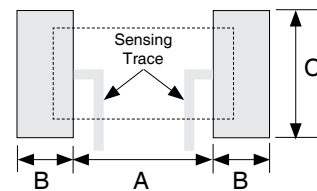

RECOMMENDED REFLOW SOLDERING TEMPERATURE PROFILE

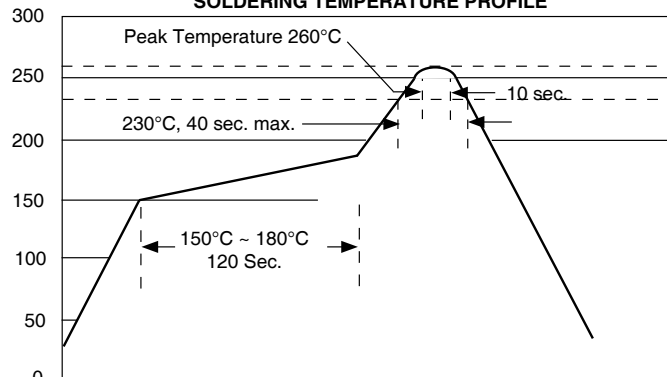

PAPER TAPE DIMENSIONS (mm)

Case Size	A	B	K	P	P ₁	E	F	D ₀	W	Quantity per Reel
0805	1.6 ± 0.15	2.4 ± 0.2	0.84 ± 0.1	4.0 ± 0.1	4.0 ± 0.1	1.75 ± 0.1	3.5 ± 0.05	1.5 ^{+0.1/-0}	8.0 ± 0.2	5,000
1206	2.0 ± 0.15	3.6 ± 0.2	0.84 ± 0.1	4.0 ± 0.1	4.0 ± 0.1	1.75 ± 0.1	3.5 ± 0.05	1.5 ^{+0.1/-0}	8.0 ± 0.2	5,000

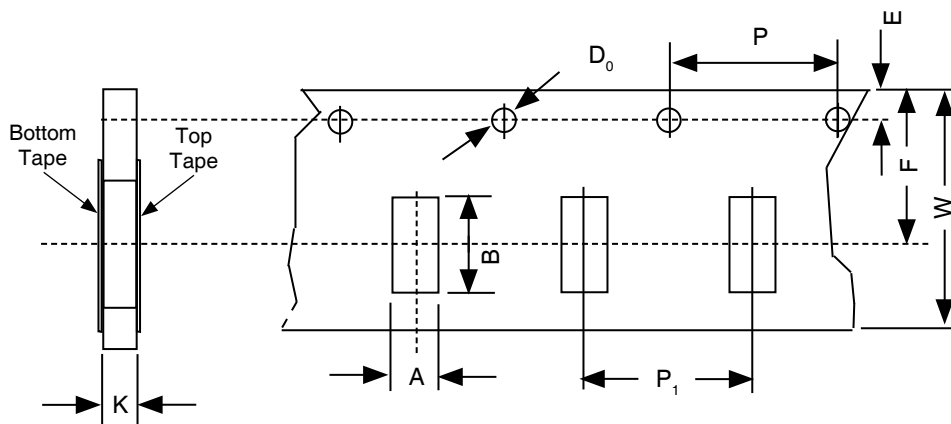

EMBOSSED PLASTIC TAPE DIMENSIONS (mm)

Case Size	A	B	K	P	P ₁	E	F	D ₀	D ₁	W	Quantity per Reel
2010	2.8 ± 0.2	5.3 ± 0.2	0.85 ± 0.15	4.0 ± 0.05	4.0 ± 0.1	1.75 ± 0.1	5.5 ± 0.05	1.5 ± 0.1	1.5 min.	12.0 ± 0.2	4,000
2512	3.6 ^{+0.2/-0.18}	6.9 ± 0.2	0.85 ± 0.15	4.0 ± 0.05	4.0 ± 0.1	1.75 ± 0.1	5.5 ± 0.05	1.5 ^{+0.1/-0}	1.5 min.	12.0 ± 0.2	4,000

